

# SPECIFICATIONS

## HX220LR

Tier 4 Final Engine

### Net Power

SAE J1349 / 173 HP  
(129 kW) at 1,950 rpm

### Bucket Range

0.52 m<sup>3</sup> (0.68 yd<sup>3</sup>)

### Operating Weight

24,820 kg (54,720 lb)

ENGINE	
Make / model	Cummins QS6.7
Type	4-cycle turbocharged, charge air-cooled, diesel engine
Rated flywheel horsepower	J1995 (gross) 182.6 HP (136 kW) at 1,950 rpm
SAE horsepower	J1349 (net) 173 HP (129 kW) at 1,950 rpm
Max. torque	85.7 kgf·m (620 lbf·ft) at 1,500 rpm
Bore X stroke	107 x 124 mm (4.2" x 4.9")
Piston displacement	6,700 cc (409 in <sup>3</sup> )
Batteries	2 x 12 V x 100 Ah
Starting motor	24 V - 4.8 kW
Alternator	24 V - 95 Amp

### HYDRAULIC SYSTEM

MAIN PUMP	
Type	Variable-displacement tandem axis piston pumps
Max. flow	2 x 222 l/min (58.6 gpm)
Sub-pump for pilot circuit	Gear pump

### CROSS-SENSING AND FUEL-SAVING PUMP SYSTEM

HYDRAULIC MOTORS	
Travel	Two-speed axial piston motor with brake motor with automatic brake
Swing	Axial piston motor with automatic brake

### RELIEF VALVE SETTING

Implement circuits	350 kgf/cm <sup>2</sup> (4,980 psi)
Travel	350 kgf/cm <sup>2</sup> (4,980 psi)
Boom	400 kgf/cm <sup>2</sup> (5,690 psi)
Arm	300 kgf/cm <sup>2</sup> (4,270 psi)
Bucket	280 kgf/cm <sup>2</sup> (3,980 psi)
Swing circuit	265 kgf/cm <sup>2</sup> (3,770 psi)
Pilot circuit	40 kgf/cm <sup>2</sup> (570 psi)
Service valve	Installed

### HYDRAULIC CYLINDERS

No. of cylinders bore X stroke	Boom: 120 x 1,290 mm (4.7" x 50.8")
	Arm: 140 x 1,570 mm (5.5" x 59.4")
	Bucket: 120 x 1,055 mm (4.7" x 41.5")

### DRIVES & BRAKES

Drive method	Fully hydrostatic type
Drive motor	Axial piston motor, in-shoe design
Reduction system	Planetary reduction gear
Max. drawbar pull	20,200 kgf (44,530 lbf)
Max. travel speed (high / low)	5.5 km / hr (3.41 mph) / 3.6 km / hr (2.23 mph)
Gradeability	35° (70%)
Parking brake	Multi wet disc brake

### CONTROL

Pilot pressure operated joysticks provide very-low-effort operation.

Pilot control	Two joysticks with one safety lever (LH): Swing and arm (RH): Boom and bucket (ISO)
Traveling and steering	Two levers with pedals
Engine throttle	Electric, dial type



### OPERATING WEIGHT (APPROXIMATE)

Operating weight, including 8.2 m (26' 11") boom and 6.3 m (20' 8") arm, SAE heaped 0.52 m<sup>3</sup> (0.68 yd<sup>3</sup>) bucket, lubricant, coolant, full fuel tank, full hydraulic tank, max 4,500 kg (9,920 lb) counterweight and all other standard equipment.

### OPERATING WEIGHT

Shoes	Operating weight		Ground pressure
Type	Width mm (in)	kg (lb)	kgf/cm <sup>2</sup> (psi)
Triple grouser	800 (32")	HX220LR 24,820 (54,720)	0.39 (5.55)

### SWING SYSTEM

Swing motor	Fixed displacement axial piston motor
Swing reduction	Planetary gear reduction
Swing bearing lubrication	Grease-bathed
Swing brake	Multi wet disc brake
Swing speed	10.8 rpm

### SERVICE REFILL CAPACITIES

	liters	US gal
Refilling		
Fuel tank	400	106
Engine coolant	40	10.6
Engine oil	23	6.1
Swing device	6.2	1.64
Final drive (each)	4.5	1.2
Hydraulic system (including tank)	275	72.6
Hydraulic tank	160	42.3
DEF/AdBlue®	27	7.1

### UNDERCARRIAGE

The X-leg type center frame is integrally welded with reinforced box-section track frames. The undercarriage includes lubricated rollers, idlers, track adjusters with shock-absorbing springs and sprockets, and a track chain with double or triple grouser shoes.

Center frame	X-leg type
Track frame	Pentagonal box type
No. of shoes on each side	49 EA
No. of carrier rollers on each side	2 EA
No. of track rollers on each side	9 EA
No. of rail guards on each side	2 EA

# SPECIFICATIONS HX220LR

Tier 4 Final Engine

## HX220LR DIMENSIONS

Unit: mm (ft-in)

8.2 m (26' 11") boom and 6.3 m (20' 8") arm

A	Overall length	12,030 (39' 6")
B	Overall width, with 800 mm shoe	3,190 (10' 6")
C	Overall height of boom	3,280 (10' 9")
D	Superstructure width	2,740 (9' 0")
E	Overall height of cab	2,920 (9' 7")
F	Ground clearance of counterweight	1,060 (3' 6")
G	Engine cover height	2,469 (8' 1")
G'	Overall height of handrail	3,211 (10' 6")

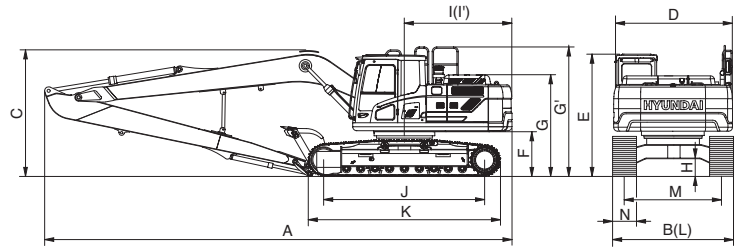

220F2R203

H	Minimum ground clearance	480 (1' 7")
I	Rear-end distance	2,770 (9' 1")
I'	Rear-end swing radius	2,840 (9' 4")
J	Distance between tumbler	3,650 (12' 0")
K	Undercarriage length	4,440 (14' 7")
L	Undercarriage width	3,190 (10' 6")
M	Track gauge	2,390 (7' 10")
N	Track shoe width	800 (32")

## HX220LR WORKING RANGE

Unit : mm (ft-in)

A	Max. digging reach	15,220 (50' 0")
A'	Max. digging reach on ground	15,120 (49' 7")
B	Max. digging depth	11,760 (38' 7")
B'	Max. digging depth (8' level)	11,650 (38' 3")
C	Max. vertical wall digging depth	9,610 (31' 6")
D	Max. digging height	12,550 (41' 2")
E	Max. dumping height	10,280 (33' 8")
F	Min. swing radius	4,870 (16' 0")

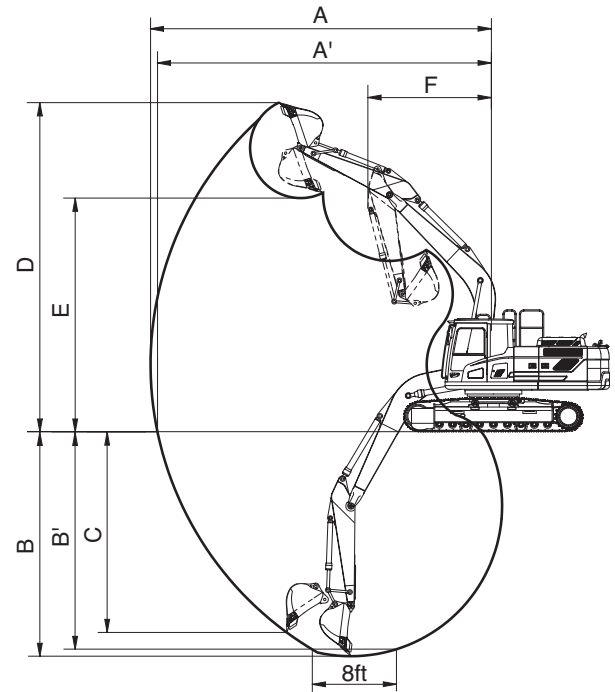

## DIGGING FORCE

Boom	Length	mm (ft-in)	8,200 (26' 11")
	Weight	kg (lb)	2,105 (4,460)
Arm	Length	mm (ft-in)	6,300 (20' 8")
	Weight	kg (lb)	1,100 (2,430)
Bucket digging force	SAE	kN	72.6
		kgf	7,400
		lbf	16,310
	ISO	kN	83.4
		kgf	8,500
		lbf	18,740
Arm crowd force	SAE	kN	49.0
		kgf	5,000
		lbf	11,020
	ISO	kN	50.0
		kgf	5,100
		lbf	11,240

Note : Boom weight includes arm cylinder, piping, and pin  
Arm weight includes bucket cylinder, linkage, and pin

# SPECIFICATIONS HX220LR

Tier 4 Final Engine

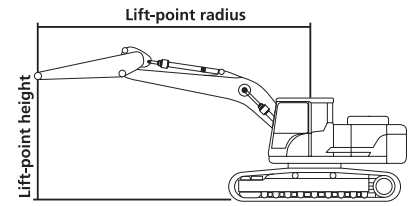

## Lifting Capacity

Boom: 8.2 m (26' 11")

Arm: 6.3 m (20' 8")

Bucket: 0.52 m<sup>3</sup> (0.68 yd<sup>3</sup>) SAE heaped

Shoe 800 mm (32") triple grouser, CWT 4,500 kg (9,920 lb)

Capacities based on North American Standard Configuration in accordance with ISO condition 2 standard.



Rating over front



Rating over side or 360 degree

Load point height (m / ft)		Lift-point radius										At max. reach							
		4.5 m (15 ft)		6.0 m (20 ft)		7.5 m (25 ft)		9.0 m (30 ft)		10.5 m (35 ft)		12.0 m (40 ft)		13.5 m (45 ft)		Capacity		Reach	
																		m (ft)	
10.5 m (35 ft)	kg																*1,470	*1,470	12.11
	lb																*3,240	*3,240	-39.7
9.0 m (30 ft)	kg											*930	*930				*1,490	*1,490	13.11
	lb											*2,050	*2,050				*3,280	*3,280	-43
7.5 m (25 ft)	kg											*1,540	*1,540				*1,530	1,350	13.84
	lb											*3,400	*3,400				*3,370	2,980	-45.4
6.0 m (20 ft)	kg									*1,590	*1,590	*1,600	*1,600				*1,580	1,190	14.37
	lb									*3,510	*3,510	*3,530	*3,530				*3,480	2,620	-47.1
4.5 m (15 ft)	kg									*1,770	*1,770	*1,710	*1,710	*1,260	*1,260		*1,630	1,080	14.72
	lb									*3,900	*3,900	*3,770	*3,770	*2,780	*2,780		*3,590	2,380	-48.3
3.0 m (10 ft)	kg					*2,500	*2,500	*2,200	*2,200	*2,000	*2,000	*1,860	1,670	*1,590	1,260		*1,700	1,010	14.89
	lb					*5,510	*5,510	*4,850	*4,850	*4,410	*4,410	*4,100	3,680	*3,510	2,780		*3,750	2,230	-48.9
1.5 m (5 ft)	kg	*5,570	*5,570	*3,900	*3,900	*3,060	*3,060	*2,560	*2,560	*2,240	2,050	*2,030	1,570	*1,790	1,200		*1,780	970	14.9
	lb	*12,280	*12,280	*8,600	*8,600	*6,750	*6,750	*5,640	*5,640	*4,940	4,520	*4,480	3,460	*3,950	2,650		*3,920	2,140	-48.9
Ground Line	kg	*6,930	6,870	*4,720	4,590	*3,580	3,320	*2,910	2,490	*2,490	1,910	*2,200	1,480	*1,820	1,140		*1,860	960	14.75
	lb	*15,280	15,150	*10,410	10,120	*7,890	7,320	*6,420	5,490	*5,490	4,210	*4,850	3,260	*4,010	2,510		*4,100	2,120	-48.4
-1.5 m (-5 ft)	kg	*7,750	6,340	*5,330	4,220	*4,020	3,060	*3,220	2,320	*2,700	1,790	*2,350	1,400	*1,570	1,100		*1,960	990	14.42
	lb	*17,090	13,980	*11,750	9,300	*8,860	6,750	*7,100	5,110	*5,950	3,950	*5,180	3,090	*3,460	2,430		*4,320	2,180	-47.3
-3.0 m (-10 ft)	kg	*8,150	6,120	*5,720	4,000	*4,330	2,890	*3,450	2,190	*2,870	1,700	*2,460	1,340				*2,060	1,050	13.92
	lb	*17,970	13,490	*12,610	8,820	*9,550	6,370	*7,610	4,830	*6,330	3,750	*5,420	2,950				*4,540	2,310	-45.7
-4.5 m (-15 ft)	kg	*8,220	6,060	*5,890	3,910	*4,490	2,810	*3,590	2,120	*2,960	1,660	*2,490	1,330				*2,180	1,170	13.2
	lb	*18,120	13,360	*12,990	8,620	*9,900	6,190	*7,910	4,670	*6,530	3,660	*5,490	2,930				*4,810	2,580	-43.3
-6.0 m (-20 ft)	kg	*8,020	6,130	*5,840	3,920	*4,500	2,790	*3,600	2,110	*2,940	1,660						*2,310	1,370	12.25
	lb	*17,680	13,510	*12,870	8,640	*9,920	6,150	*7,940	4,650	*6,480	3,660						*5,090	3,020	-40.2
-7.5 m (-25 ft)	kg	*7,500	6,310	*5,550	4,010	*4,300	2,850	*3,420	2,170	*2,700	1,730						*2,430	1,710	10.97
	lb	*16,530	13,910	*12,240	8,840	*9,480	6,280	*7,540	4,780	*5,950	3,810						*5,360	3,770	-36
-9.0 m (-30 ft)	kg	*6,570	*6,570	*4,920	4,200	*3,790	3,000	*2,890	2,320										
	lb	*14,480	*14,480	*10,850	9,260	*8,360	6,610	*6,370	5,110										
-10.5 m (-35 ft)	kg	*4,970	*4,970	*3,680	*3,680														
	lb	*10,960	*10,960	*8,110	*8,110														

NOTES:

- Lifting capacities are based on ISO 10567.
- Lifting capacity of the HX Series does not exceed 75% of tipping load with the machine on firm, level ground or 87% of full hydraulic capacity.
- The Lift-point is bucket pivot mounting pin on the arm (without bucket mass).
- (\*.) indicates load limited by hydraulic capacity.

# SPECIFICATIONS HX220LR

Tier 4 Final Engine

ENGINE	STD	OPT
Cummins QSB 6.7 engine	•	
HYDRAULIC SYSTEM		
Intelligent Power Control (IPC)		
3-power mode, 2-work mode, user mode	•	
Variable power control	•	
Pump flow control	•	
Attachment mode flow control	•	
Engine auto idle	•	
Engine auto shutdown control		•
Electronic fan control	•	
CAB & INTERIOR		
ISO standard cabin		
Rise-up type windshield wiper	•	
Radio / USB player	•	
Bluetooth / hands-free mobile phone system with USB	•	
Miracast	•	
12-volt power outlet (24 V DC to 12 V DC converter)	•	
Electric horn	•	
All-weather steel cab with 360° visibility	•	
Safety glass windows	•	
Sliding fold-in front window	•	
Sliding side window (LH)	•	
Lockable door	•	
Hot and cool box	•	
Storage compartment and ashtray	•	
Transparent cabin roof-cover	•	
Sun visor	•	
Door and cab locks, one key	•	
Mechanical suspension seat with heater	•	
Pilot-operated adjustable joystick	•	
Console box height adjust system	•	
Cabin lights	•	
Cabin front window rain guard		•
Cabin roof-steel cover		•
Automatic climate control		
Air conditioner and heater	•	
Defroster	•	
Starting aid (air grid heater) for cold weather	•	
Centralized monitoring		
8" LCD display	•	
Engine speed or trip meter / accel.	•	
Engine coolant temperature gauge	•	
Max. power	•	
Low speed / high speed	•	
Auto idle	•	
Overload		•
Check engine	•	
Air cleaner clogging	•	
Indicators	•	
ECO gauges	•	
Fuel level gauge	•	
Hydraulic oil temperature gauge	•	
Fuel warmer	•	
Warnings	•	
Communication error	•	
Low battery	•	
Clock	•	

CAB & INTERIOR	STD	OPT
Seat		
Adjustable air suspension seat with heater	•	
Cabin FOPS/FOG		
FOG ISO 10262 Level 2	Front and top guard	•
(FOPS ISO 3449 Level 2)	Top guard	•
Cabin ROPS		
ROPS ISO 12117-2	•	

SAFETY	STD	OPT
Battery master switch	•	
Rearview camera	•	
AAVM (All-Around View Monitoring)		•
Four front working lights (2 boom mounted, 2 front frame mounted)	•	
Dual boom working lights	•	
Travel alarm	•	
Rear work lamp		•
Beacon lamp		•
Automatic swing brake	•	
Boom holding system	•	
Arm holding system	•	
Safety lock valve for boom cylinder with overload warning device		•
Safety lock valve for arm cylinder		•
Swing lock system		•
Three outside rearview mirrors	•	

OTHER	STD	OPT
Booms		
5.68 m, 18' 8"	•	
8.2 m, 26' 11" Long reach	•	
Arms		
2.0 m, 6' 7"		•
2.4 m, 7' 10"		•
2.92 m, 9' 7"	•	
3.9 m, 12' 10"		•
6.3 m, 20' 8" Long reach	•	
Removable clean-out dust net for cooler	•	
Removable reservoir tank	•	
Fuel pre-filter	•	
Fuel warmer		•
Self-diagnostics system	•	
Hi-mate remote management system		Mobile Satellite
Batteries (2 x 12 V x 100 Ah)	•	
Fuel-filler pump (50 ℓ/min / 13 gpm)		•
Single-acting piping kit (breaker, etc.)		•
Double-acting piping kit (clamshell, etc.)	•	
Rotating piping kit		•
Quick coupler piping		•
Quick coupler		•
Boom float control		•
One-pedal straight travel system		•
Pilot accumulator	•	
Pattern change valve (SAE and ISO)	•	
Fine swing control system		•
Tool kit		•

UNDERCARRIAGE	STD	OPT
Lower frame under cover (additional)		•
Lower frame under cover (normal)	•	
Track shoes		
Triple grousers shoes (700 mm, 28")		•
Triple grousers shoes (800 mm, 32")	•	
Triple grousers shoes (900 mm, 36")		•
Track rail guard	•	
Full track rail guard		•

NOTE: Standard and optional equipment may vary. Materials and specifications are subject to change without advance notice. Contact your Hyundai dealer for more information.

## PLEASE CONTACT



www.hceamericas.com

6100 Atlantic Blvd., Norcross, GA 30071

TEL (678) 823 7777 FAX (678) 823 7778