

# OPERATING INSTRUCTIONS

**DINO XT II**  
**160 • 180 • 210**

**Manufacturer:**

Dinolift Oy  
Raikkolantie 145 | FI-32210 LOIMAA  
Tel. + 358 20 1772 400 | [info@dinolift.com](mailto:info@dinolift.com) | [www.dinolift.com](http://www.dinolift.com)

---

---

**TRANSLATION OF THE ORIGINAL INSTRUCTIONS****Valid from serial number**

<b>160XT II</b>	<b>17681,17735,17743-&gt;</b>
<b>180XT II</b>	<b>30450 -&gt;</b>
<b>210XT II</b>	<b>3824 -&gt;</b>

## CONTENTS

<b>1.</b>	<b>TO THE OPERATOR .....</b>	<b>7</b>
1.1.	OVERVIEW OF THE UNIT.....	8
1.2.	INTENDED USE OF THE WORK PLATFORM.....	8
<b>2.</b>	<b>TECHNICAL SPECIFICATIONS.....</b>	<b>9</b>
2.1.	DIMENSION DRAWINGS .....	11
2.1.1.	160 XT II .....	11
2.1.2.	180 XT II .....	12
2.1.3.	210 XT II .....	13
2.2.	REACH DIAGRAM.....	14
2.2.1.	160 XT II .....	14
2.2.2.	180 XT II .....	15
2.2.3.	210 XT II .....	16
2.3.	EXAMPLE OF THE MACHINE'S NAMEPLATE .....	17
2.4.	EXAMPLE OF EU DECLARATION OF CONFORMITY.....	18
2.5.	SAMPLE OF INSPECTION PROTOCOL FOR THE ACCESS PLATFORM	19
<b>3.</b>	<b>SAFETY .....</b>	<b>21</b>
3.1.	SAFETY INSTRUCTIONS .....	21
3.2.	SAFETY-RELATED NOTIFICATIONS.....	25
3.3.	SAFETY LABELS .....	27
3.4.	SAFETY DEVICES .....	30
<b>4.</b>	<b>STRUCTURE AND FUNCTIONS OF THE LIFT.....</b>	<b>34</b>
4.1.	STRUCTURE OF THE LIFT.....	34
4.2.	FUNCTIONS OF THE LIFT.....	35
4.3.	OPERATING CONTROLS FOR THE FUNCTIONS .....	36
4.3.1.	Operating controls in the chassis control centre.....	36
4.3.2.	Operating controls for the outriggers .....	37
4.3.3.	Optional controls on the chassis.....	37
4.3.4.	Operating controls in the platform control centre UCB .....	38
4.3.5.	Setup with two control levers (option).....	39
<b>5.</b>	<b>USING THE LIFT .....</b>	<b>40</b>
5.1.	STARTING UP.....	40
5.1.1.	Worksite inspection.....	40
5.1.2.	Positioning the lift.....	41
5.1.3.	Starting up .....	42
5.1.4.	Supporting the lift.....	44

5.2. OPERATION.....	45
5.2.1. Operating the lift from the chassis control centre .....	45
5.2.2. Operating the lift from the platform control centre .....	46
5.2.3. Special instructions for winter use .....	49
5.2.4. Ending the work .....	49
5.3. TRANSFERRING THE LIFT .....	50
5.3.1. Preparing the lift for transport .....	50
5.3.2. Using the driving device.....	51
5.3.3. Towing the lift.....	53
5.3.4. Tying down.....	54
5.3.5. Lifting the device.....	55
5.4. LONG-TERM STORAGE.....	55
<b>6. DINO SKY RACK (OPTION) .....</b>	<b>56</b>
6.1. IN CASE OF EMERGENCY .....	58
6.1.1. When at risk of losing the stability .....	58
6.1.2. In case of overloading.....	58
6.1.3. In case of power failure.....	58
6.1.4. In case of malfunction, when even the emergency descent system is not operational .....	59
<b>7. INSTRUCTIONS FOR FAULT-FINDING .....</b>	<b>60</b>
<b>8. MAINTENANCE SCHEDULE .....</b>	<b>64</b>
8.1. SCHEDULE FOR INSPECTIONS REQUIRED BY THE AUTHORITIES ....	66
8.2. LUBRICATION PLAN .....	67
<b>9. ROUTINE MAINTENANCE DURING OPERATION .....</b>	<b>68</b>
9.1. INSTRUCTIONS FOR DAILY MAINTENANCE AND INSPECTIONS .....	69
9.1.1. Check the condition of chassis, the boom and the work platform.....	69
9.1.2. Check the tyres and tyre pressure .....	69
9.1.3. Check the lights .....	69
9.1.4. Check the hydraulic oil level .....	69
9.1.5. Check the hydraulic hoses, pipes and connectors .....	69
9.1.6. Check the operation of the safety limit switches.....	70
9.1.7. Check the operation of the emergency descent, the emergency stop and the sound signal.....	70
9.1.8. Decals, stickers and signs .....	70
9.1.9. Instruction manuals.....	70
<b>10. CHANGE OF OWNER .....</b>	<b>73</b>



BLANK

## 1. TO THE OPERATOR

Keep this manual on the work platform of the lift in the box reserved for it. If the instruction manual gets lost, damaged, or for some other reason becomes unreadable, order a new manual from the manufacturer.

This manual is intended to familiarise the user with the structure and functions of the work platform, as well as with its appropriate use. The manual provides guidance on the service measures that are the responsibility of the user of the work platform.

Other maintenance procedures on the work platform require special skills, special tools or accurate knowledge about measurements or adjusted values. Guidance for these measures is provided in a separate service manual. For situations that require service or repair measures, contact the authorised service provider, importer or manufacturer.



### **DANGER**

Read all the instructions in this manual before using the aerial work platform. Make sure that you have understood all the instructions. The instructions must absolutely be followed during operation and maintenance of the aerial work platform.

When handling the unit, in addition to the instructions in this manual, the user must also observe the local legislation, the guidelines stipulated by the employer, and regulations valid at the work site.

### **NOTICE**

Information that only applies to a specific model version, feature or equipment, will have the identification included in the title. Check the applicability of such information to your machine.

Dinolift Oy is constantly developing its products. For this reason, the contents of this manual might not always be in full compliance with the most recent version of the product. Dinolift Oy reserves the right to modify the product without prior notice. Dinolift Oy assumes no liability for any problems caused by changed or missing data or mistakes in this manual.

Please consult your dealer or the manufacturer for more information and detailed instructions.

## 1.1. OVERVIEW OF THE UNIT

This unit is a trailer mounted, towable aerial work platform.

This aerial work platform complies with the standard EN280 type 1. Moving the lift by means of the driving device or by towing is possible only when the lift is in the transport position.

For the operation, the tyres of the lift shall be raised off the ground by means of the hydraulic outriggers.

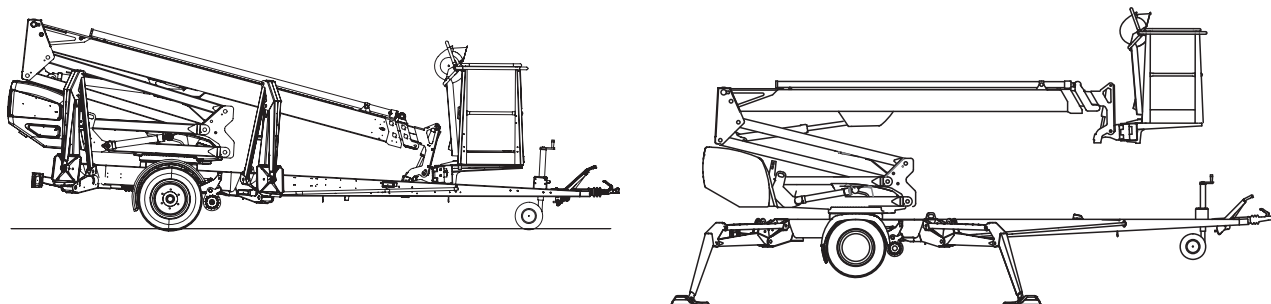

The primary power source of the lift is the electric motor. The outriggers and the boom system are hydraulically powered.

As an option, the lifts can be equipped with a hydraulic driving device.

Consult the chapters “Technical data” and “Structure and functions of the work platform” in this manual for more detailed information about the lift.

## 1.2. INTENDED USE OF THE WORK PLATFORM

The aerial work platform is exclusively intended for transferring people and tools to the work position and acting as a work platform within its permissible load-bearing capacity and reach (refer to the “Technical Specifications” table and the “Reach Diagram”).

The intended use also covers:

- Following all the instructions in the Operating Instructions
- Performance of the inspections and maintenance operations.
- Observation of the occupational safety regulations and road traffic regulations.

This aerial work platform is NOT insulated, and does not offer protection against contact with electric current. The aerial work platform must not be used for work on electric systems.

Observe the safety instructions concerning the operating environment, and the restrictions given in them,

### **NOTICE**

**The operator must receive instructions and consent from the manufacturer for all such specific work methods or conditions that the manufacturer has not explicitly defined in the unit's operation and maintenance instructions.**



## 2. TECHNICAL SPECIFICATIONS

	160XT II	180XT II	210XT II
Max. working height	16,0 m	18,0 m	21,0 m
Max. platform height	14,0 m	16,0 m	19,0 m
Max. outreach	9,1 m	11,2 m	11,7 m
Boom rotation	continuous		
Platform rotation	180°		
Turn area	refer to the reach diagram		
Support width	3,80/4,20 m	3,90/4,30 m	3,90/4,30 m
Transport width	1,80 m	1,95 m	1,95 m
Transport length	6,15 m	6,66 m	7,92 m
Transport height	2,30 m	2,30 m	2,33 m
Weight (incl. Honda power unit)	1992 kg	2315 kg	2478 kg
Max. allowed load on platform	215 kg		
Max. number of persons + additional load	2 persons + 55 kg		
Max. allowed sideways load (caused by persons)	400 N		
Max. lateral inclination (chassis)	±0,3°		
Max. allowed gradient of ground to the side	2,2°	6,7°	6,7°
Max. allowed gradient of ground lengthwise	3,8°	8,0°	8,3°
Max. wind speed during operation	12,5 m/s		
Min. ambient temperature when working	- 20 °C		
Max. support force on the outriggers	16800 N	16800 N	22800 N
Platform size	0,7 x 1,3 m		
Gradeability	25%		
Socket outlets on the platform	2 x 230V/50Hz/16A		
Power supply	0	0	0
- mains current	230V/50Hz/10A		
Sound pressure level	< 70 dB		
Whole-body vibration	Not detectable		
- Engine (Honda)	GX200		
Sound pressure level (UCB/LCB)	73 / 90 dB		
Whole-body vibration	< 0,5 m/s <sup>2</sup>		
- Engine (Hatz)	1B30-X		
Sound pressure level (UCB/LCB)	76 / 94 dB		
Whole-body vibration	< 0,5 m/s <sup>2</sup>		

### Optional engines

<b>Hatz 1B30</b>		<b>EPA / CARB Tier 4 Final</b>
Fuel	Diesel	
Net power	4,4 kW (6 hp) / 2800 r/min	
Oil tank volume	1,1 l	

<b>Honda GX200SXE</b>	
Fuel	Petrol
Net power	4,1 kW (5,5 hp)
Fuel tank volume	3,1 l
Oil volume	0,6 l
Fuel consumption	1,7 l/h

## 2.1. DIMENSION DRAWINGS

### 2.1.1. 160 XT II

Rev.	Muutos	Pvm.	Muut	Hyv.
A	Takavaropaneelin tummukset korjattu ja mitoitus muutettu alkamaan vetokoukun keskistä.	3.6.2016	TN	
B	Lisätty LED-valojen mitoitus kuvanto	28.6.2016		
C	Versions added, dimensioning changed	7.6.2018	JK	

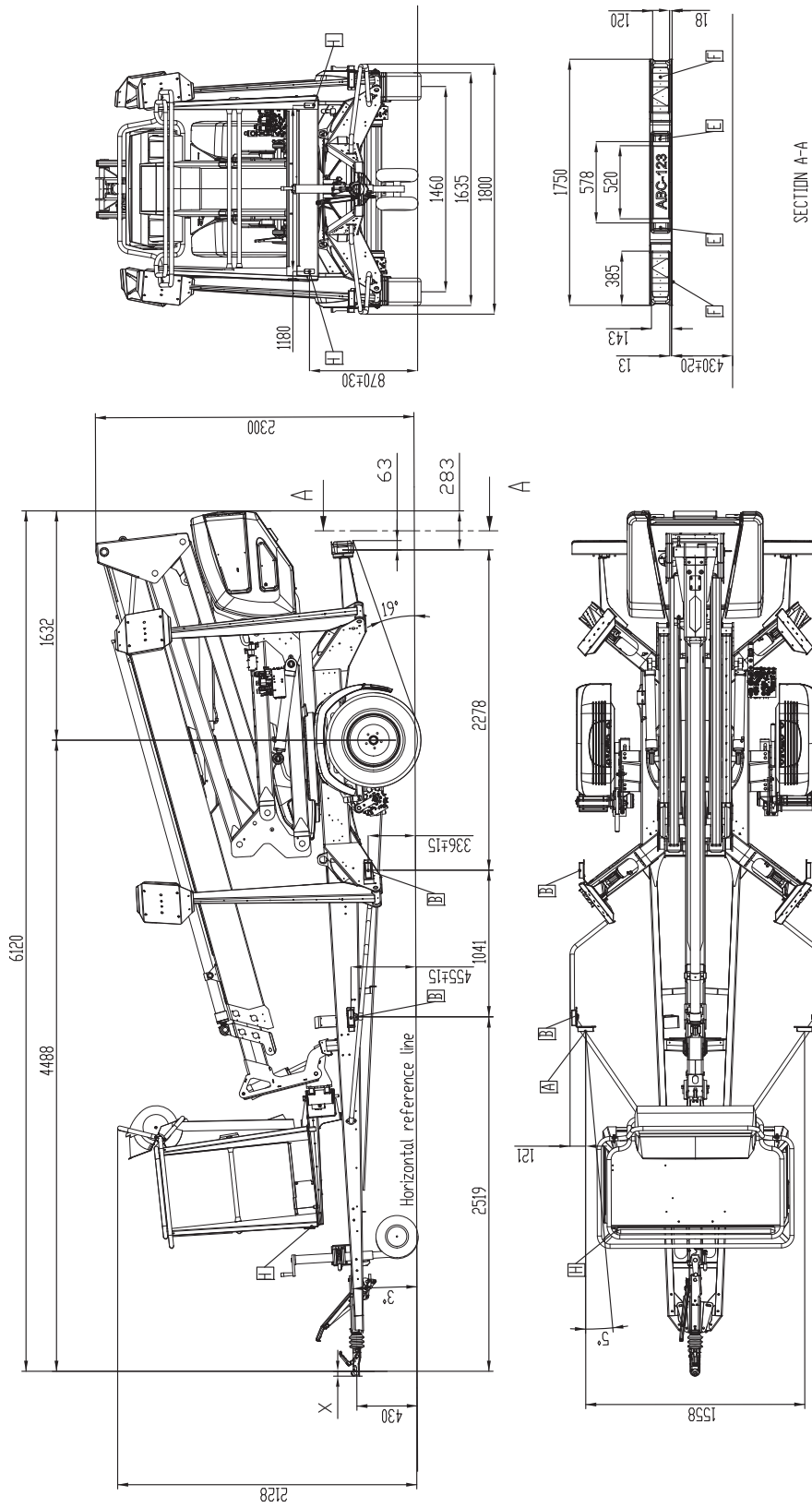

Version	Dimension	Value
D20-4300	X	35
D20-4270	X	45

DIND LIFT	
Ent.	Uusi
3CB8665	

Yleistiedot SFS-EN 22768-1 Korkeus	Mittakaava 1:30	Tuote Liftty
Part. LP 15.12.2014 Suunn. LP 5.9.2014 Hyv.	Massa 0,00	Dimensional drawing DIND 160XT, Version D20-4

Dimension tolerances +2%

2.1.2. 180 XT II

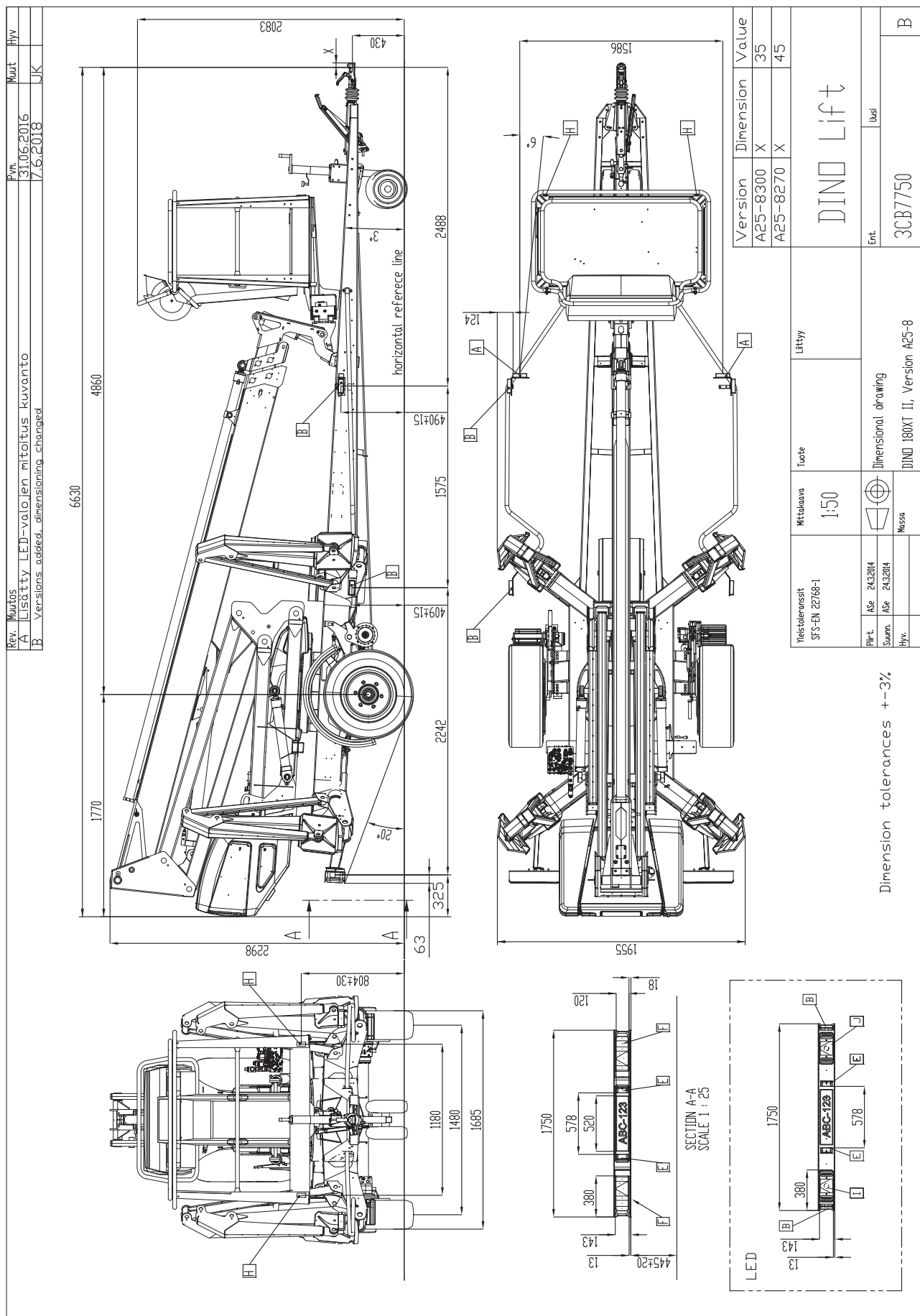

## 2.1.3. 210 XT II

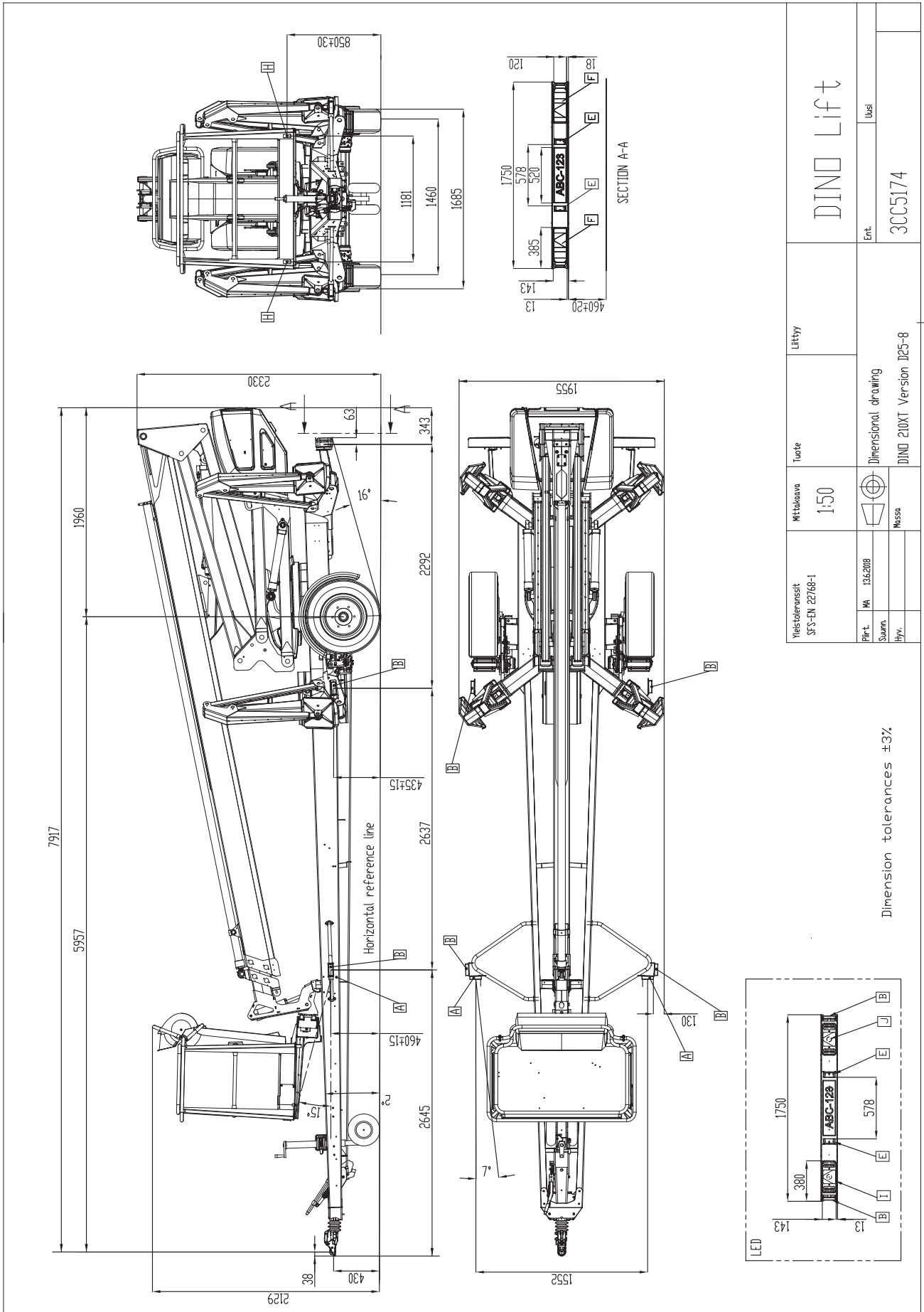

## 2.2. REACH DIAGRAM

### 2.2.1. 160 XT II

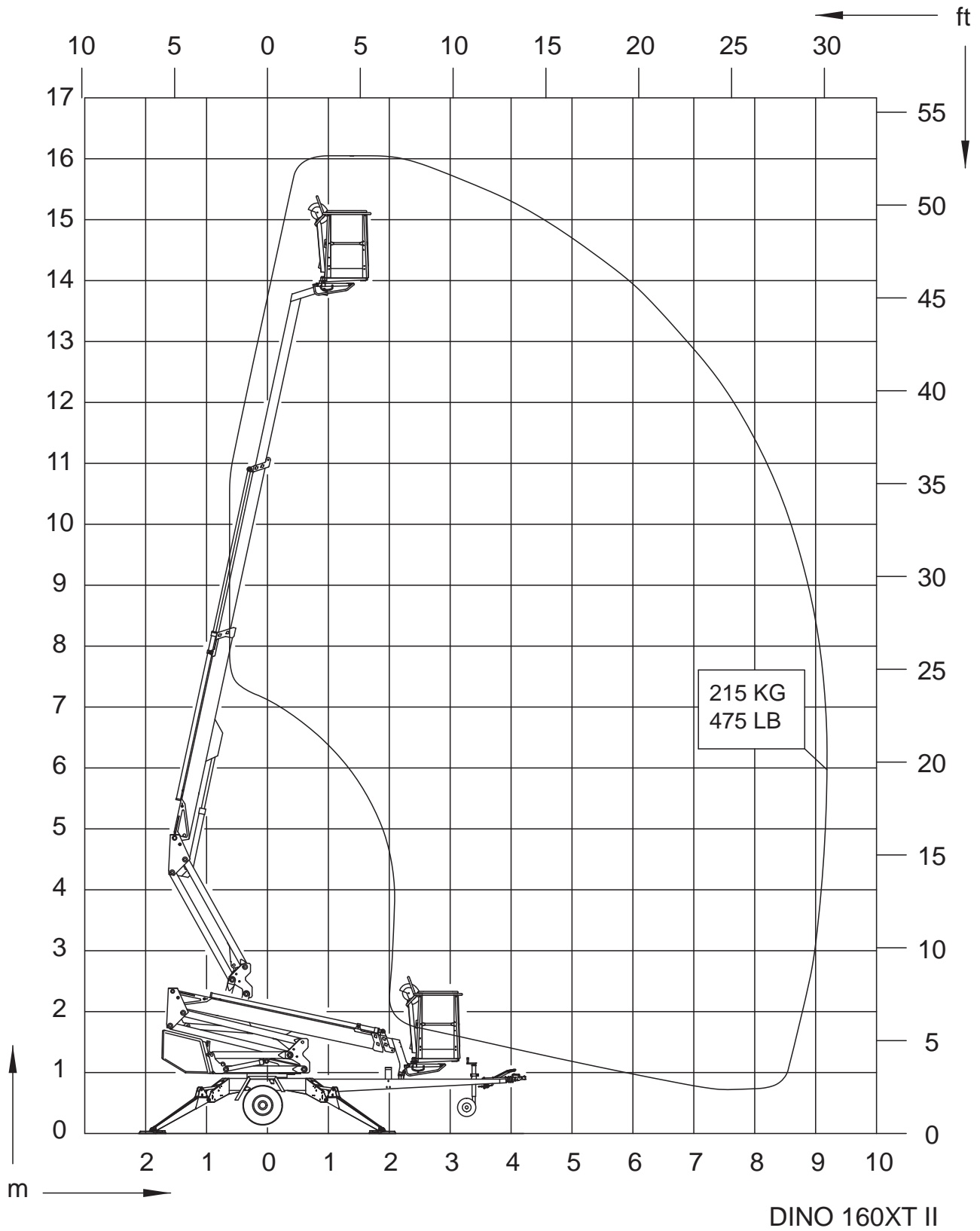

## 2.2.2. 180 XT II

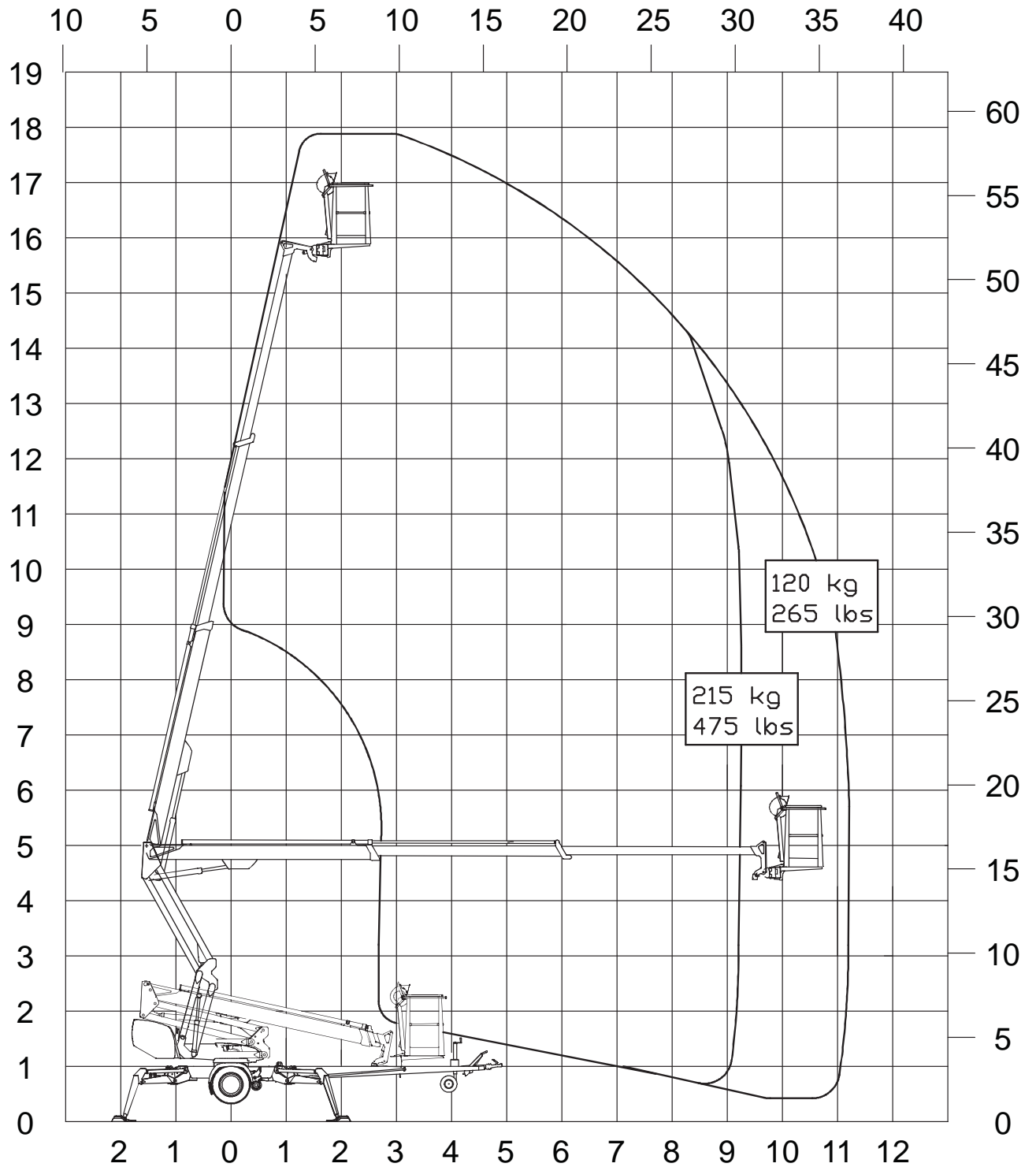

2.2.3. 210 XT II

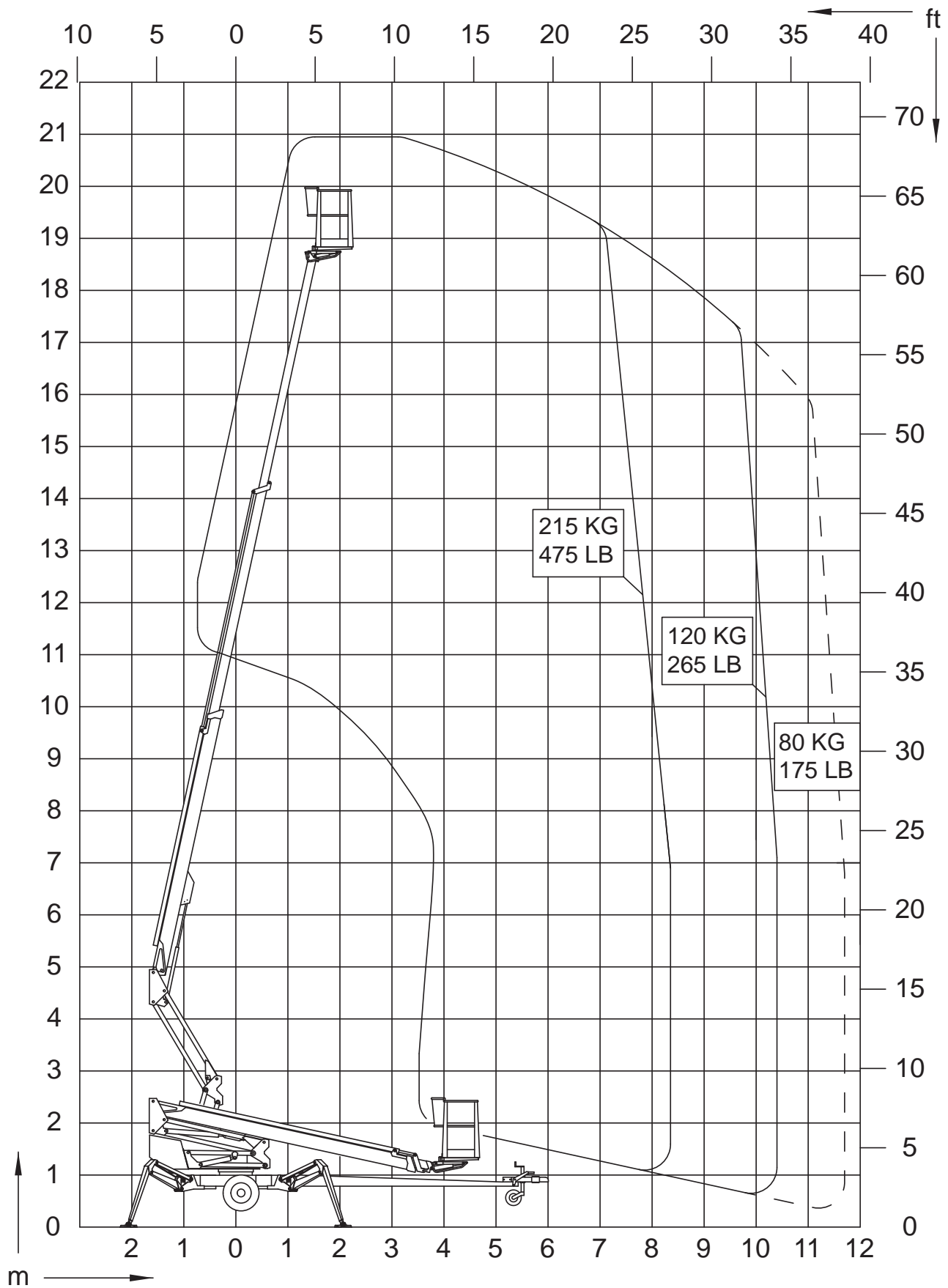



## 2.3. EXAMPLE OF THE MACHINE'S NAMEPLATE

The name of the manufacturer, and the production number and serial number of the machine have been marked on the nameplate as shown in the picture below.

Type	<b>DINO</b>		Manufacturer	<b>DINOLIFT</b>
Year of manufacture			Address of manufacture	Raikkolantie 145 32210 Loimaa FINLAND
Number of manufacture				<b>CE</b>
Weight kg			Max load	215 kg
Max load of persons		2	Additional load	55 kg
Max side force		400 N	Max inclination of chassis	0.3 °
Voltage		230 V	Frequency	50 Hz
Min operating temp.		-20 °C	Max wind force	12,5 m/s

54.516

Description of the machine marked on the plate MEWP = "Mobile Elevating Work Platform"

The nameplate of the lift is located on the right-hand side of the tow-bar, as shown in the picture.



The serial number is also engraved in the lift's chassis, on the upper surface of the right-hand tow-bar.

The nameplate of the trailer is located on the tow-bar, on the right-hand side of the nameplate of the lift, as shown in the picture.



Following data is written on the plate:

EU Type Approval Number (if available)		
Serial number		
	Total weight	kg
0	Maximum allowed weight on the towing hitch	kg
1	Maximum allowed axle weight	kg
2		kg

## 2.4. EXAMPLE OF EU DECLARATION OF CONFORMITY

### EU declaration of conformity for machine

#### Manufacturer

Dinolift Oy  
Raikkolantie 145  
FI-32210 Loimaa, FINLAND

declares that

#### **DINO 160XT-2 Access Platform no. YGCD160XTM00XXXXX**

is in conformity with the provisions of Machinery Directive **2006/42/EC** as amended and with national implementing legislation.

Manufacturer

Dinolift Oy

has assessed the conformity of the machinery with internal checks (2006/42/EC Annex VIII) and has granted a certificate No. **DCE 160XT/002/19**

Access platform also fulfils the requirements of the following EEC directives:  
**2000/14/EC, 2014/30/EU, (EU) 2016/1628**

---

	Measured sound power level Lwa	Quaranteed sound power level Lwa
Honda	(97+1,5) 98,5 dB	98,5 + 0,5 dB
Hatz	(102,5+1,5) 103,5 dB	103,5+0,5 dB

2000/14/EC Conformity assessment procedure followed: Annex V:  
Internal control of production.

Following harmonized standards have been applied in designing the machine:  
**SFS-EN 280+A1:2015; SFS-EN 60204-1/A1; SFS-EN-ISO 12100**

---

Person authorized to draw up the Technical File:

Santtu Siivola  
Chief Engineer  
Dinolift Oy, Raikkolantie 145,  
FI-32210 Loimaa, FINLAND

Loimaa

XX.XX.2020

-----  
Santtu Siivola  
Chief Engineer

## 2.5. SAMPLE OF INSPECTION PROTOCOL FOR THE ACCESS PLATFORM



TEST CERTIFICATE

DATE: 16.9.2014

www.dinolift.com

### START-UP TESTS:

Inspection place: Dinolift Oy

Inspector's signature:

1074

Koivisto Pekka NT0153

### BASIC KNOWLEDGE

Manufacturer: Dinolift OY

Place of manufacture: Finland

Address: Raikkolantie 145

32210 LOIMAA

Importer:

Type of lift:  Boom platform

Scissor platform

Mast platform

Chassis:  Car

Self propelled

Trailer mounted

Boom:  Articulated boom

Telescope boom

Articulated telescope boom

Scissor

Fixed mast

Telescope mast

Outriggers:  Hydraulic turning

Hydraulic pushing

Mechanical

### TECHNICAL SPECIFICATIONS

Machine and type:

DINO 180XT II

Max. platform height

16 m

Number of manufacture

YGCD180XT E2030004

Max. outreach: depend on load:

Depend on load

Year of manufacture

2014

Max. lifting capacity:

215 kg

Boom rotation:

Continuous

Max. person number:

2

Support width:

3,8 m

Max. additional load:

55 kg

Transport width:

1,95 m

Power supply:

230VAC

Transport length:

6,65 m

Lowest temperature:

-20 °C

Transport height:

2,31 m

Weight:

2315 kg

Basket size:

0,7 x 1,3 m

Inspection points:

(Y = meet standards N = do not meet standards)

	Y	N		Y	N
<b>A. STRENGTH</b>			6. Plate for supports	<input checked="" type="checkbox"/>	<input type="checkbox"/>
1. Certificate of material	<input checked="" type="checkbox"/>	<input type="checkbox"/>	7. Safety colours	<input checked="" type="checkbox"/>	<input type="checkbox"/>
2. Certificate of strength	<input checked="" type="checkbox"/>	<input type="checkbox"/>			
<b>B. STABILITY</b>			<b>D. SAFETY REQUIREMENTS</b>		
1. Certificate of stability test	<input checked="" type="checkbox"/>	<input type="checkbox"/>	1. Indicating device for horizontal position	<input checked="" type="checkbox"/>	<input type="checkbox"/>
2. Working space diagram	<input checked="" type="checkbox"/>	<input type="checkbox"/>	2. Locking device and lockings	<input checked="" type="checkbox"/>	<input type="checkbox"/>
<b>C. GENERAL REQUIREMENTS</b>			3. Stop device for lifting	<input checked="" type="checkbox"/>	<input type="checkbox"/>
1. User's manual	<input checked="" type="checkbox"/>	<input type="checkbox"/>	4. Stop for opening of support	<input checked="" type="checkbox"/>	<input type="checkbox"/>
2. Place for safekeeping for user's manual	<input checked="" type="checkbox"/>	<input type="checkbox"/>	5. Safety distances	<input checked="" type="checkbox"/>	<input type="checkbox"/>
3. Machine plate - checking plate	<input checked="" type="checkbox"/>	<input type="checkbox"/>	6. Position of working face	<input checked="" type="checkbox"/>	<input type="checkbox"/>
4. Load plate	<input checked="" type="checkbox"/>	<input type="checkbox"/>	7. Structure of working face	<input checked="" type="checkbox"/>	<input type="checkbox"/>
5. Warning plate	<input checked="" type="checkbox"/>	<input type="checkbox"/>	8. Emergency descent system	<input checked="" type="checkbox"/>	<input type="checkbox"/>
			9. Limit devices	<input checked="" type="checkbox"/>	<input type="checkbox"/>

<p><b>E. ELECTRIC APPLIANCES</b></p> <p>1. Electric appliances <input checked="" type="checkbox"/> <input type="checkbox"/></p>	<p><b>G. SAFETY DEVICE</b></p> <p>1. Safety limit switch <input checked="" type="checkbox"/> <input type="checkbox"/></p> <p>2. Sound signal <input checked="" type="checkbox"/> <input type="checkbox"/></p>
<p><b>F. CONTROL DEVICES</b></p> <p>1. Protections <input checked="" type="checkbox"/> <input type="checkbox"/></p> <p>2. Symbols / directions <input checked="" type="checkbox"/> <input type="checkbox"/></p> <p>3. Placings <input checked="" type="checkbox"/> <input type="checkbox"/></p> <p>4. Emergency stop <input checked="" type="checkbox"/> <input type="checkbox"/></p>	<p><b>H. LOADING TEST</b></p> <p>1. Overload test = 323 kg (150%) <input checked="" type="checkbox"/> <input type="checkbox"/></p> <p>2. Funktional test = 237 kg (110%) <input checked="" type="checkbox"/> <input type="checkbox"/></p>
<p>FAILINGS AND NOTES _____</p> <p>_____</p> <p>_____</p>	
<p>Failings have been repaired.      Date: _____      Signature: _____</p>	

**Dinolift Oy**  
 Raikkolantie 145  
 FIN-32210 LOIMAA, FINLAND  
 Tel. +358 - 20 - 1772 400, Fax +358 - 2 - 7627 160, e-mail: info@dinolift.com

The initial inspection and test loading of the Dino aerial work platforms is performed by the manufacturer. A protocol, drawn up during the inspection, will accompany the lift.

The protocols of the start-up and periodic inspections must be kept with the lift or its immediate proximity for at least five years.

### 3. SAFETY

All the essential safety instructions and warnings, relevant to transport, use and maintenance of the lift, are described in this chapter.



## **DANGER**

Failure to observe these instructions and safety regulations may cause a severe injury or even death. Familiarise yourself with all the safety regulations, operating instructions and signs affixed to the machine, and follow them.

Make sure that you understand all the safety instructions and regulations. Also make sure that others operating the machine or working on the work platform are familiar with these instructions.

#### 3.1. SAFETY INSTRUCTIONS

Only specially trained personnel with authorisation in writing, who are well familiarised with the device, and at least 18-years old, are allowed to operate the unit.

Keep the lift free of any dirt, which may impair safe operation, and impede the inspection of the structures.

The device must be serviced and inspected regularly.

Only skilled persons, familiar with the service and repair instructions, are allowed to carry out servicing and repair work.

It is strictly prohibited to use a lift which is out of order.

Never remove or disable any safety devices of the machine.



## **WARNING**

The device must neither be altered without the manufacturer's consent nor be used under conditions, which do not meet the manufacturer's requirements.

The operator must receive instructions and consent from the manufacturer for all such specific work methods or conditions that the manufacturer has not explicitly defined.

## TRANSFERS

Observe the maximum allowed gradient when transferring the lift. During transfer in rough terrain, always try to position yourself higher than the machine.

Beware of fixed or moving obstacles in the terrain or near the lift while driving. Make sure that you have a clear view of the driving path.

Do not use the machine for towing.

## WORK AREA AND PREPARATIONS BEFORE LIFTING WORK

When working in busy areas, the operating range of the lift must be clearly marked by using either warning lights or fencing.

Also observe the road traffic regulations.

Ensure the unobstructed range of movement before operating the outriggers.

The load-bearing capacity and the gradient of the base must be taken into account when supporting the chassis. Do not use the lift if it is on a lorry, a railway car, a floating vessel or any other potentially unstable platform.

Ensure that the outriggers cannot slide while on a gradient.

Additional support plates of adequate size must be used under the outriggers, when working on soft ground. Only use such additional support plates, on which the metallic outriggers will not slide.

While in the support position, ensure that the wheels are off the ground.

Always ensure the level position of the machine before starting the operation.

Always ensure that the work area is clear of outsiders. Danger of getting squeezed between rotating and fixed structures.

**While operating the boom from the control centre on the turning device, beware of getting pressed against the outriggers or other structures that do not turn with the boom.**

## LIFTING AND WORKING ON THE PLATFORM

Never exceed the maximum number of persons, maximal loading or hand power, allowed for the lift. Never add load onto the platform while in the upper position.

Before operating, always ensure that the safety devices and the emergency descent system are in working order.

**Use the safety harness!** Fix the safety harness to the fixing points, intended for the purpose.

Note! The platform is fitted with a fixing point for the safety harness of each user. Only one harness per fixing point.

Do not use ladders, steps or other similar equipment on the platform.

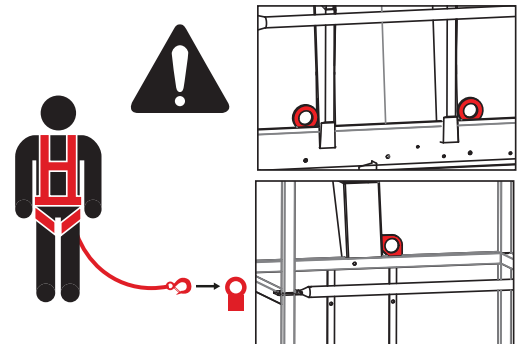

Ensure that the gates are properly closed before starting the operation. If the work platform is equipped with ladder, these must be locked in the upper position.

Never throw or drop any objects from the platform. All the tools must be transported on the inside of the platform. Never leave the tools hanging outside the work platform, supported only by their power cord.

Do not lift the tools, accessories or other material on the railing of the platform or attached to the railing.

The aerial work platform must not be used for lifting.

The work platform must not be used for transferring goods or persons between different floors or working levels. Stepping on or off the platform in motion is prohibited.

When the boom is in its lowest positions, make sure it cannot clash during rotation with structures that do not turn with the boom.

Always make sure, before lowering the platform, that the area under it is clear.

Avoid damaging the platform by lowering it on the ground, or bringing it in contact with any structures.

Never use a lift alone. Make sure that there is always someone on the ground, who can call for help in case of an emergency.

## OPERATING CONDITIONS

The weather conditions, such as wind, visibility and rain, must always be taken into account so that these will not adversely affect the safe performance of the lifting operations.



**The use of the lift is prohibited, if the temperature drops under -20 °C or the wind speed exceeds 12.5 m/s**

Wind speed ( m/s)		Conditions on land
0	Calm	Smoke rises vertically
1-3	Light breeze	Smoke moves with the wind and the wind feels on exposed skin. Leaves rustle.
4-7	Gentle breeze	Leaves and small branches of trees are moving. Flag is flying. Wind lifts dust and loose pieces of paper from the ground.
8-13	Strong breeze	Small broad-leaved trees and large branches sway. Wind whistles as it hits houses or other fixed objects. Umbrella is difficult to use.
14-17	Strong	All the trees are swaying. It is difficult. to walk against the wind.

NOTE! The wind speed can be much higher at a higher altitude than on the ground level.

Do not take tools/material of large surface area onto the platform. The increase in wind load may jeopardize the stability of the device.

**Beware of the live aerial power lines in the area – observe the minimum safety distances:**

Voltage range (phase to phase)	Minimum distance	
	Metres	Feet
0–300 V	Avoid contact	
300 V–50 kV	3	10
50 kV–200 kV	4.5	15
200 kV–350 kV	6	20
350 kV–500 kV	8	25
500 kV–750 kV	11	35
750 kV–1000 kV	14	45

These distances shall apply unless more stringent limits are given in worksite instructions or in local or governmental regulations.

This aerial work platform is NOT insulated, and does not offer protection against contact with electric current. The aerial work platform must not be used for work on electric systems.



### 3.2. SAFETY-RELATED NOTIFICATIONS

The following safety alert symbols and safety signal words are used in this manual.

Observe all the safety instructions that follow these symbols, in order to avoid dangerous situations and personal injuries.



This is a general safety alert symbol and it is used to alert you about a potential hazard. Observe the additional instructions given in form of text or symbols that follow this symbol.



## **DANGER**

Red DANGER-message warns for an imminent or potential hazardous situation which, if not avoided, may result in death or serious injury.



## **WARNING**

Orange WARNING -message is used in connection with potential risk factors, which if not avoided, under certain conditions, may result in death or serious injury.



## **CAUTION**

Yellow CAUTION -message is used to warn about a hazardous situation which, if not avoided, could result in minor or moderate injury.

## **NOTICE**

Blue notice-message is used to draw your attention to special notifications or instructions that are related to the operation or maintenance. Such messages include, for example, instructions that are related to reliability of the machine or aim to avoid material losses.



Risk of getting crushed  
- moving parts



Risk of getting crushed  
- moving parts



Risk of getting crushed  
- falling objects

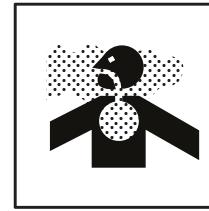

Harmful exhaust gas  
emissions

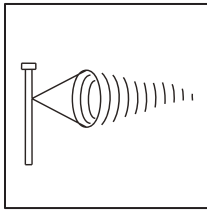

Wind speed



Risk of turning over

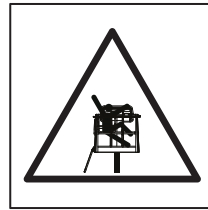

Risk of falling

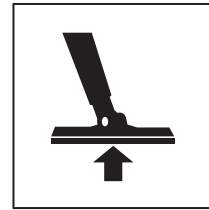

Support force



Smoking prohibited

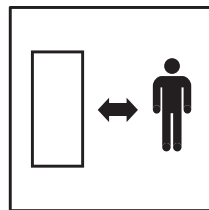

Keep safe distance

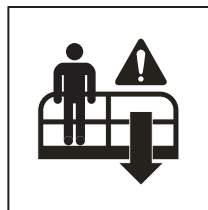

Emergency descent

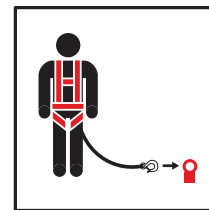

Fixing point for the  
falling guard



Open flame prohibited

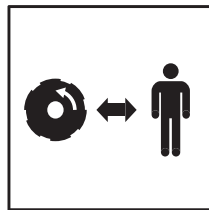

Keep safe distance

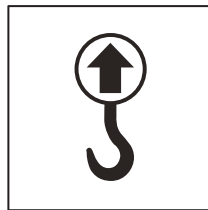

Lifting point

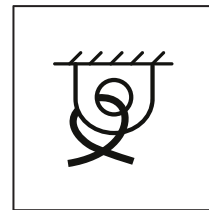

Fixing point



Running the engine  
indoors prohibited

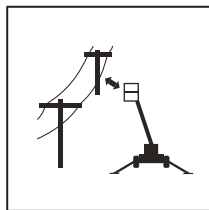

Keep safe distance to  
the power lines

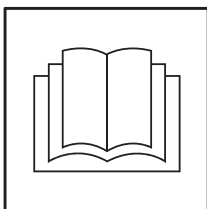

Operating instructions

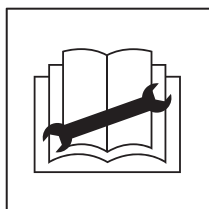

Maintenance  
instructions

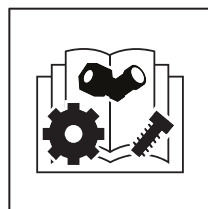

Spare parts catalog

## 3.3. SAFETY LABELS

(ANSI/CSA/AS/NZS) The following safety labels must be intact, clean and legible. Replace the labels if necessary. CE Safety labels and all instructional labels are listed in the spare parts list.

**US 54.1058**

**US 54.1061**

**US 54.1060**

**US/CAN 54.1049**

**AS/NZ 54.1660**

**54.180**

**US 54.1046**

**54.1605**

**US 54.1582**

**US 54.1061**

**54.1042**

**US 54.1061**

**US 54.1061**



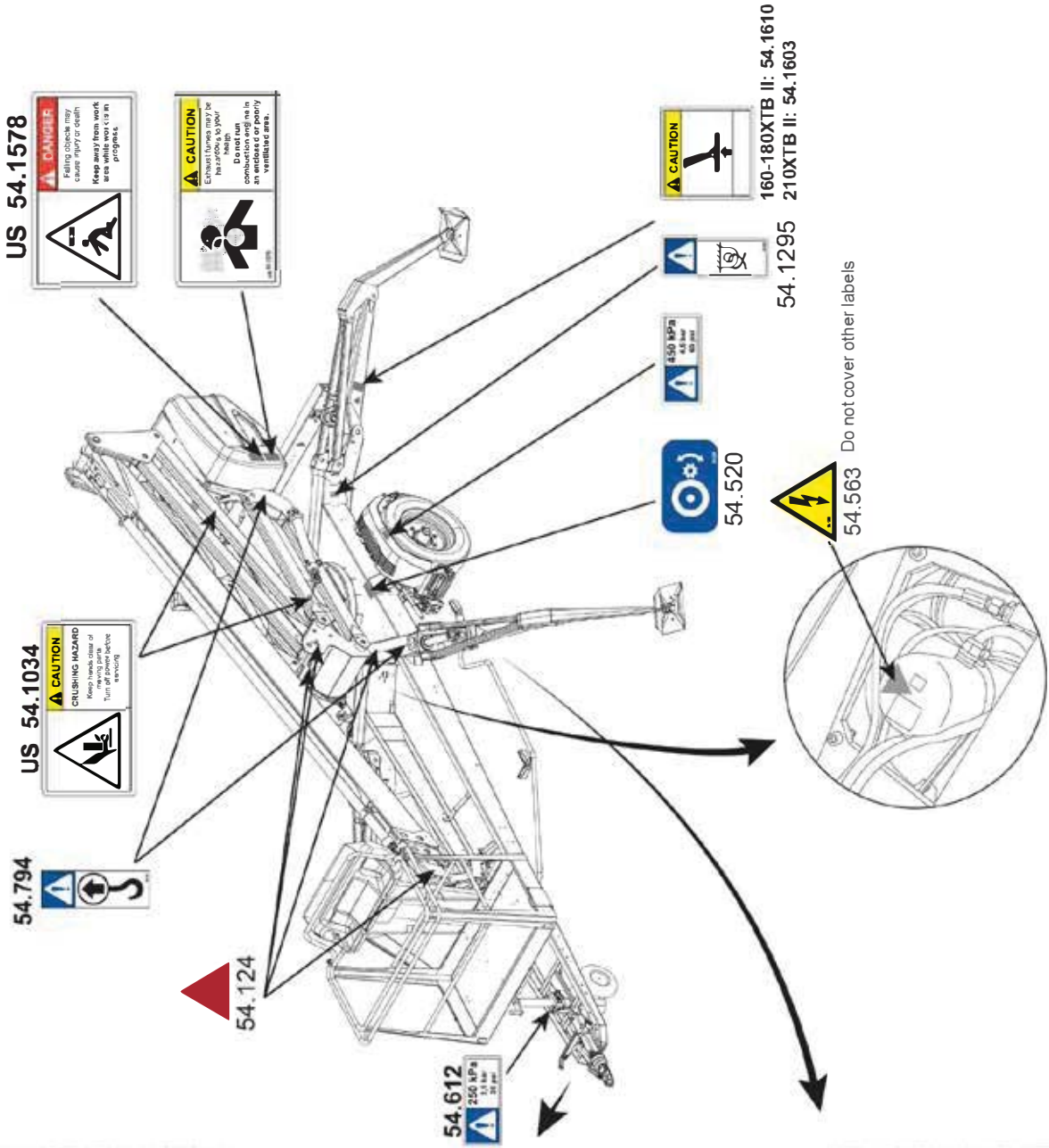
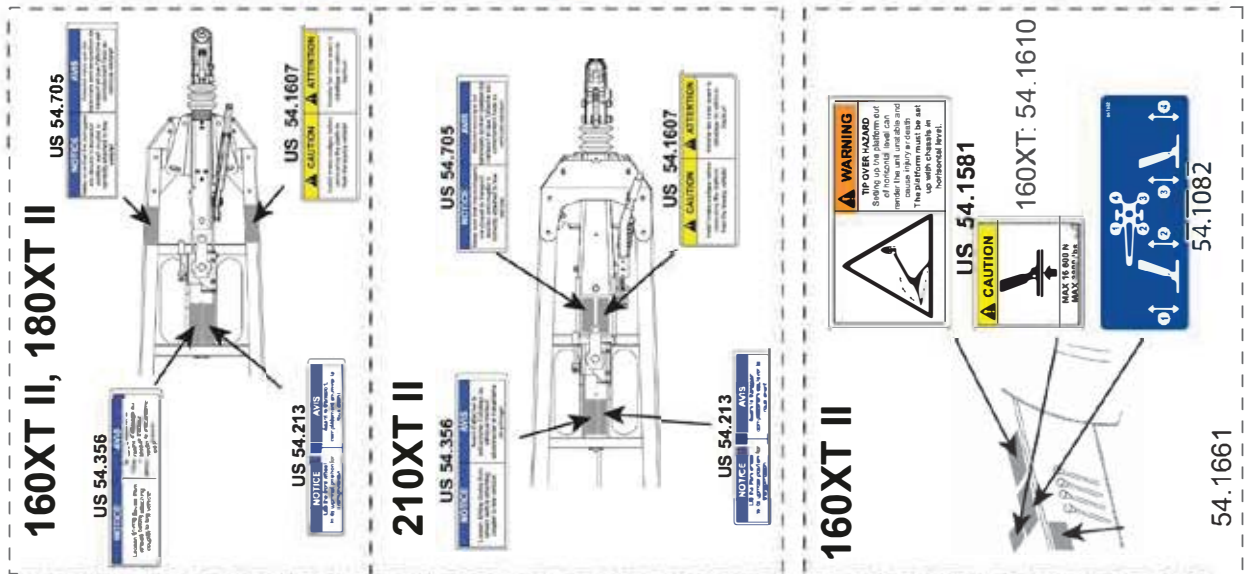



### 3.4. SAFETY DEVICES

#### 1. Supervision of transport position of the boom

The safety limit switch RK3 prevents the operation of the outriggers and the driving device when the boom is not resting on the transport support. The switch is located on the tow-bar at the transport support.

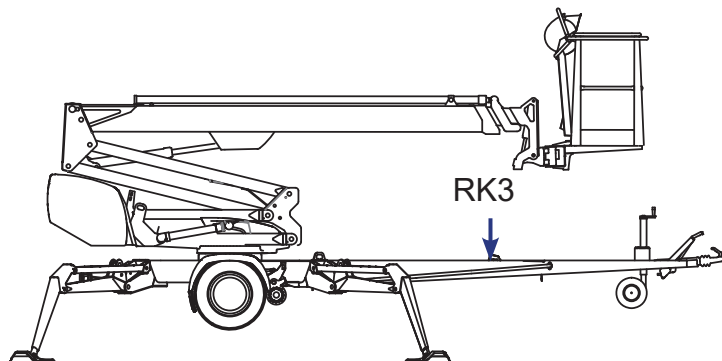

If the supervision of transport position is not functioning properly, the engine will stop. The defect must be repaired before the operation can be resumed.

#### 2. Supervision of supporting

The lift's all support outriggers must be in the support position before the boom is lifted. Make sure that the wheels are off the ground.

The safety limit switches RK11, RK12, RK13 and RK14 are located on the support outriggers.

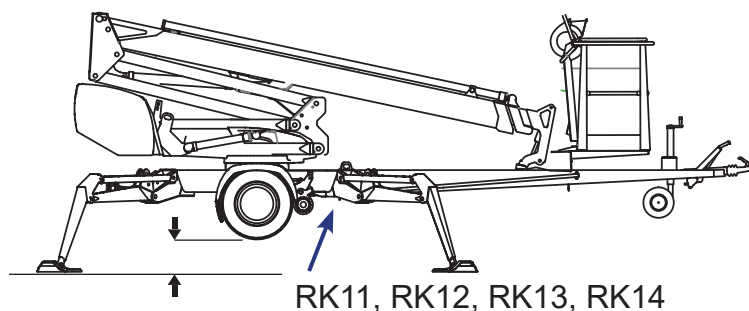

#### 3. Overload control of the boom

The outreach limit switch RK4 and overload limit switch RK5 prevent the lift from being overloaded by limiting the outreach of the lift to the side.

The limit switches are located under the cover at the top end of the lifting cylinder. During operation, the cover must be intact and in place.

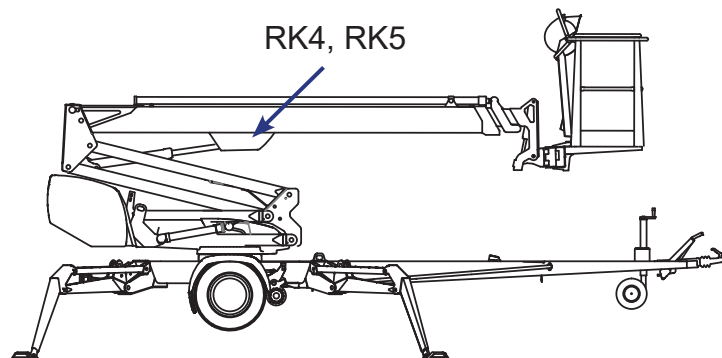

The green light in the control centre on the platform is lit, when the platform is within the allowed operating range.

The reach limit switch **RK4** will stop the movements, which impair the stability of the lift (extending the telescope and lowering the boom), at a predetermined position.

Adjusted values of the limits:

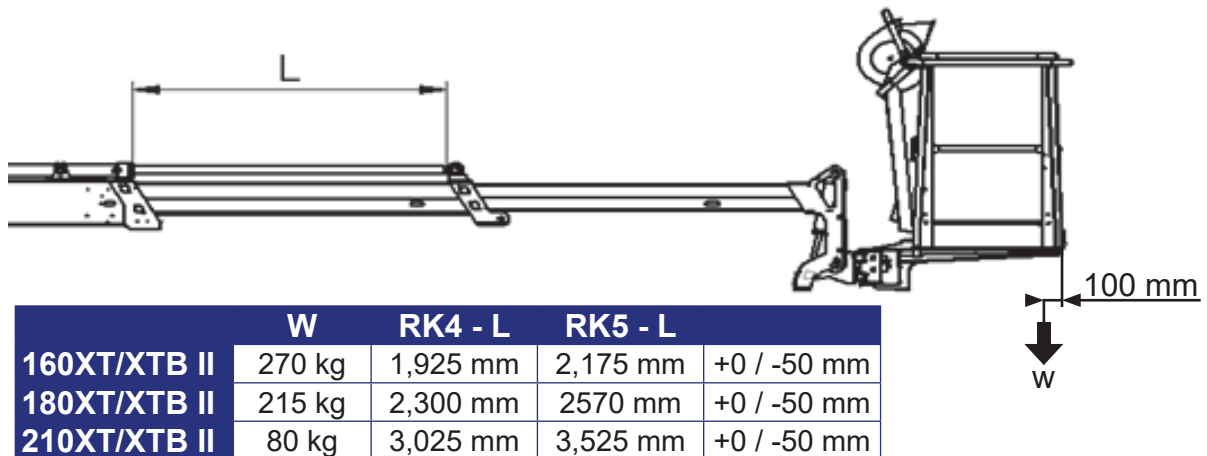

The red warning light for overloading will illuminate as soon as the **RK4** has stopped the movement. While at the outreach limit, the red warning light and the green signal light will flash in turns. In this situation, the lift can be operated in the direction, in which it remains inside the permitted outreach area.

The overload limit switch **RK5** backs up, if the **RK4**, for some reason, does not work. Once the **RK5** is activated, the red warning light for overloading in both control centres will be continually illuminated, and a warning buzzer will sound on the platform.

The operation of the overload limit switches is based on monitoring of the boom's lifting torque.

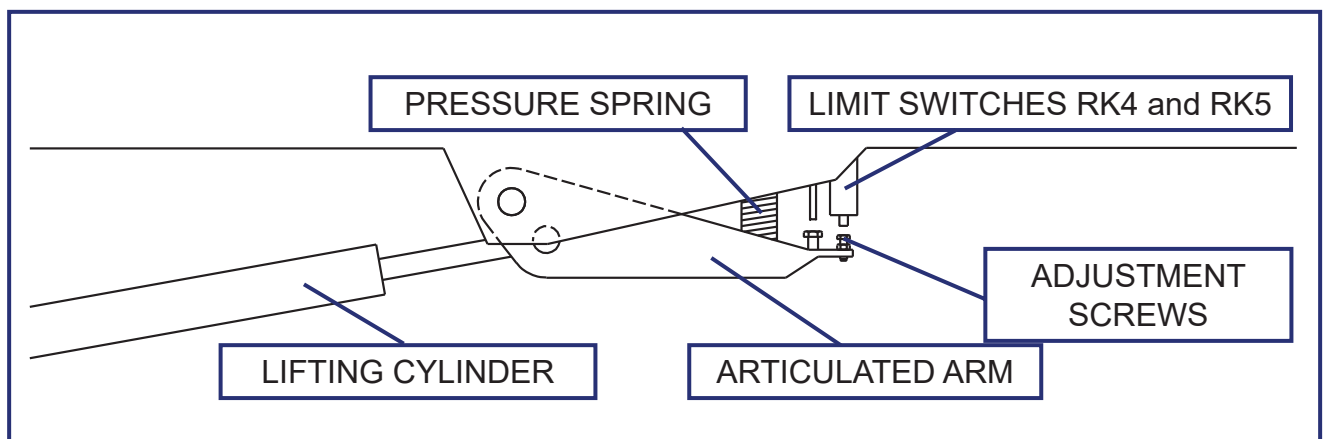

**DANGER**

The limit switches must never be readjusted, nor the operation of the mechanism be impeded. **Risk of turning over the lift!**

## 5. Supervision of the telescope chain

The extension chains for the telescope are doubled. If the load-bearing chain slackens or breaks, the doubling chain prevents the movements of the telescope, and the safety switch RK7/RK8 breaks the emergency stop circuit.

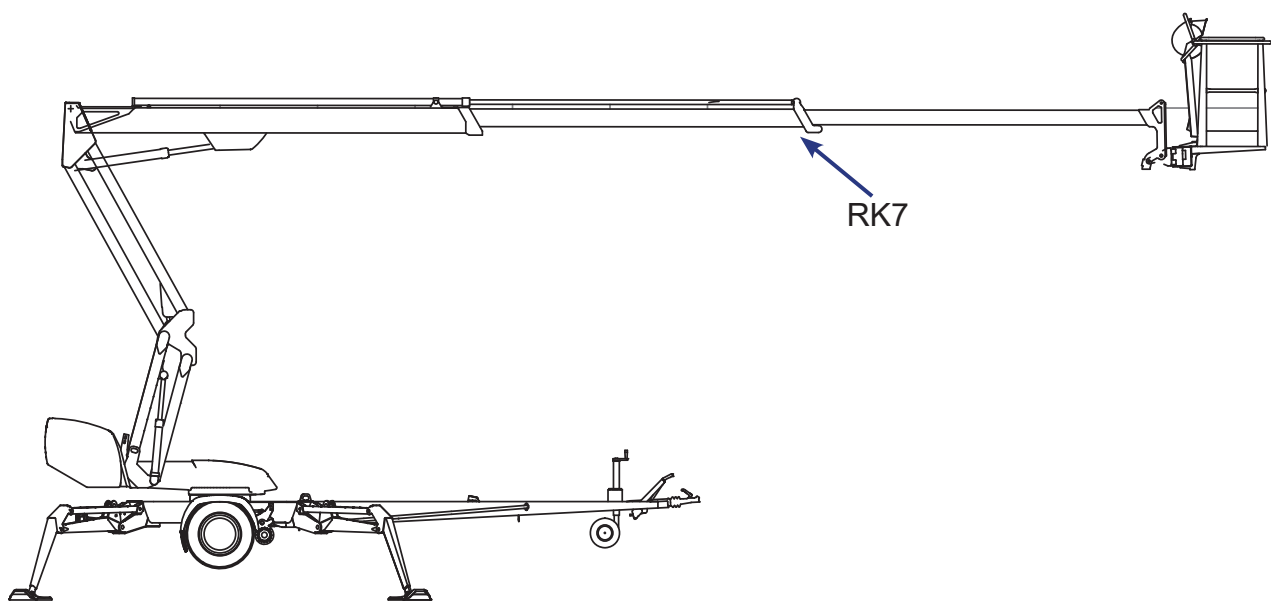
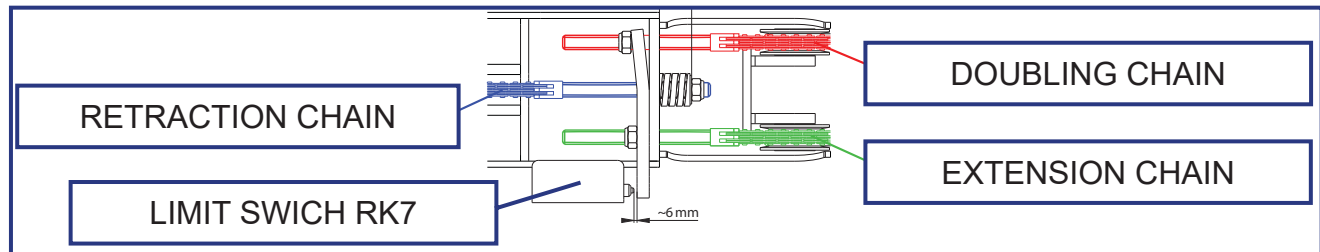

## 6. Preventing the inclination of the platform

The platform is levelled hydraulically by means of a so-called slave cylinder system, where the master cylinder controls the slave cylinder that inclines the work platform.

The levelling system comprises the following parts:

1. Master cylinder
2. Slave cylinder
3. Load regulation valve
4. Double load regulation valve
5. Electric directional valve

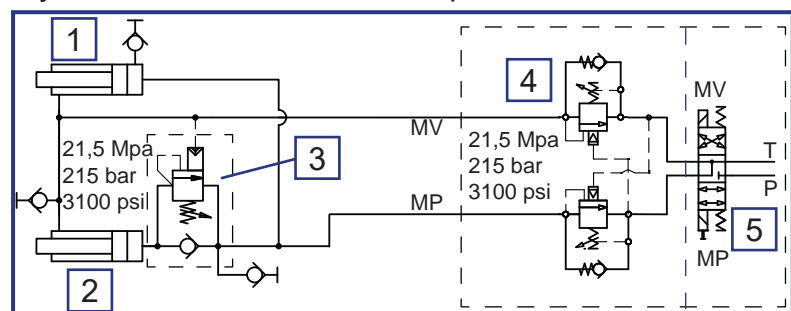



## 7. Safety devices for hose rupture

All the load-bearing cylinders are equipped with valves for rupture or leak in the hydraulic system, which prevent the load from falling.

Outrigger cylinders	Lock valves	Prevent the inching of the outriggers in either direction.
Lifting cylinder of the boom	Load regulation valve	Prevents the load from falling
Lifting cylinder of the articulated arms	Load regulation valve	Prevents the load from falling
Telescope cylinder	Load regulation valve	Prevents the inching of the telescope in either direction.
Levelling system	Load regulation valves	Prevents the inclination of the platform

## 8. Emergency stop buttons

Depressing the emergency stop button, stops all the movements immediately and turns off the power unit. The button can be found at each control station. Once the button has been depressed, only the emergency descent functions remain operational.

The emergency stop button locks in the lower position, and it must be released before starting the power unit.

### **NOTICE**

If the unit does not start, make sure that the emergency descent button is not in the lower position at any of the control stations.

The emergency stop button in the platform control centre is fitted with a signal light, which remains illuminated while the lift is in the normal operating mode. The light will go out, if the emergency stop function is activated by any of the emergency stop switches or by the safety device.

## 4. STRUCTURE AND FUNCTIONS OF THE LIFT

The denominations of the machine's essential parts and concepts, which are used later in these instructions, are described on the following pages.

### 4.1. STRUCTURE OF THE LIFT

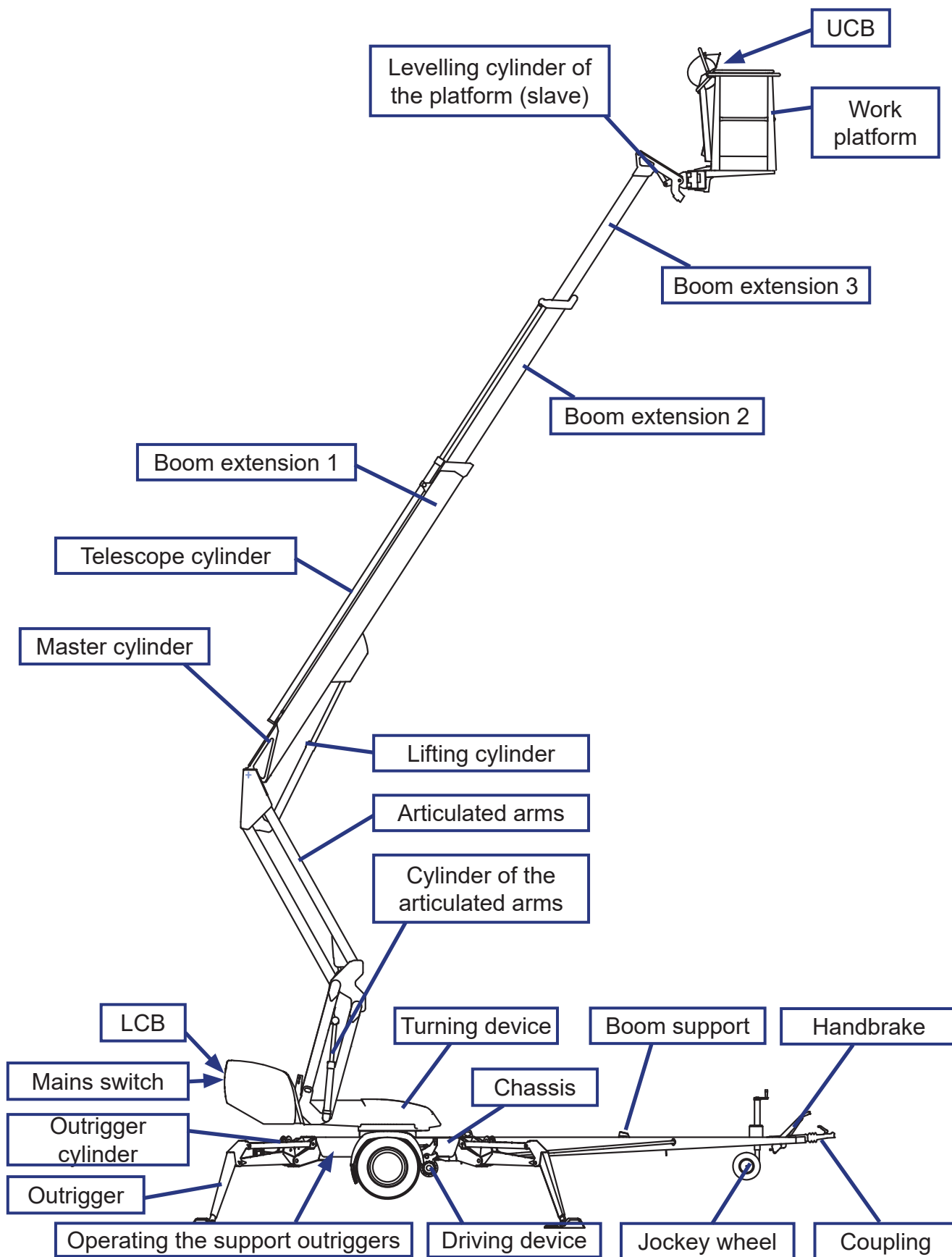

## 4.2. FUNCTIONS OF THE LIFT

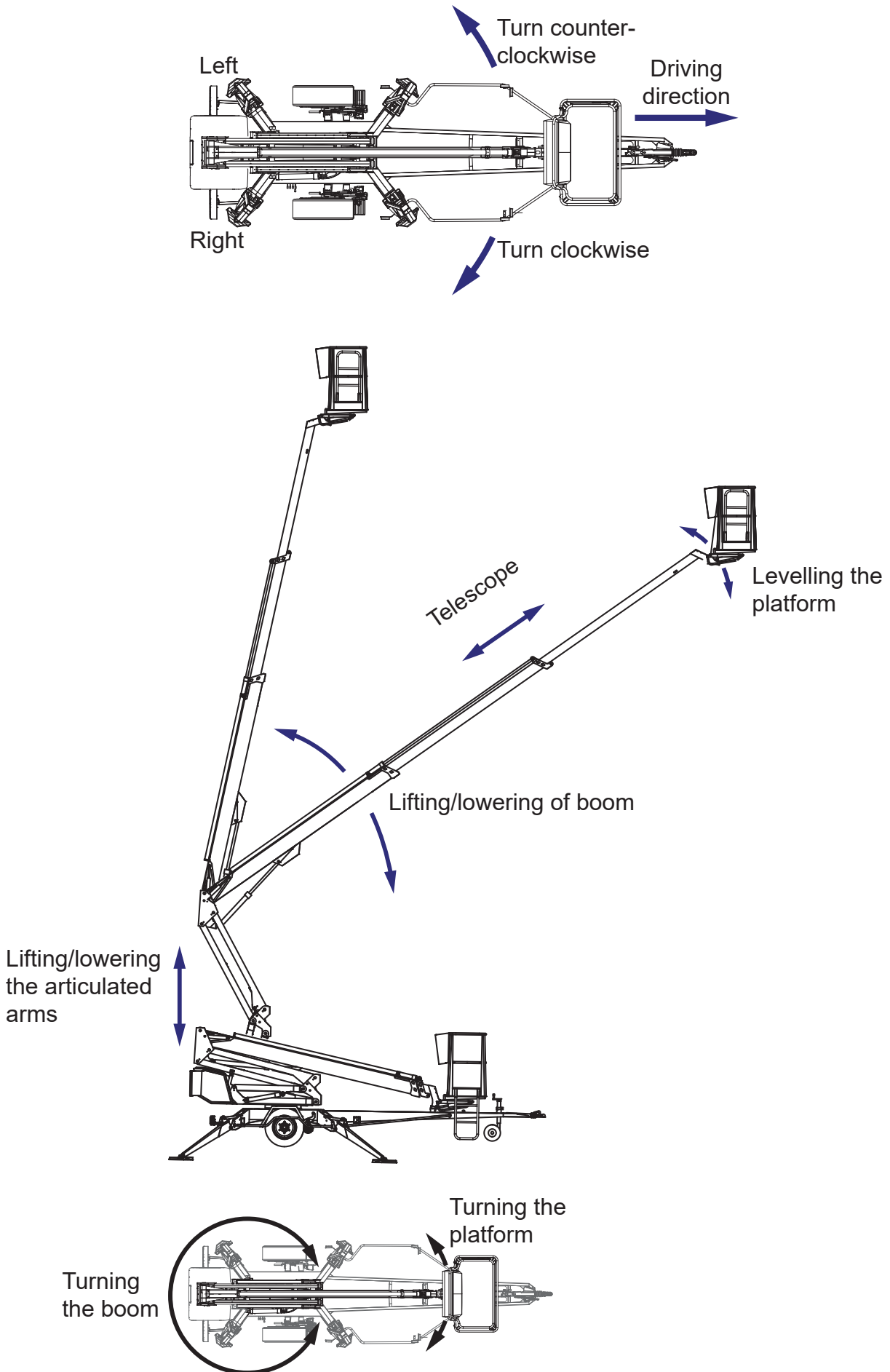

### 4.3. OPERATING CONTROLS FOR THE FUNCTIONS

#### 4.3.1. Operating controls in the chassis control centre

I 0	Starting/stopping of the motor		Starting of the emergency descent pump
	Choke		Retraction button for the telescope
S1	Emergency stop		Movement speed selector
Q1	Selector switch	<b>Rocker switches for platform and boom:</b>	
0	OFF - power off	S16	Turning the boom
1	Chassis control centre (LCB)	S17	Boom up / down
2	Platform control centre (UCB)	S18	Retracting/extending the telescope
		S19	Articulated arms up / down
	Automatic fuse for socket outlets	S20	Levelling the platform
<b>Signal lights and gauges:</b>		<b>Pushbuttons for driving:</b>	
	The outriggers are in the support position and the operation of the boom is allowed.	S26	Drive forward
	Overloading or the load is at the outreach limit	S27	Drive backward
U1	Voltage meter	S24	Turning to the left.
HM1	Hour meter	S25	Turning to the right.

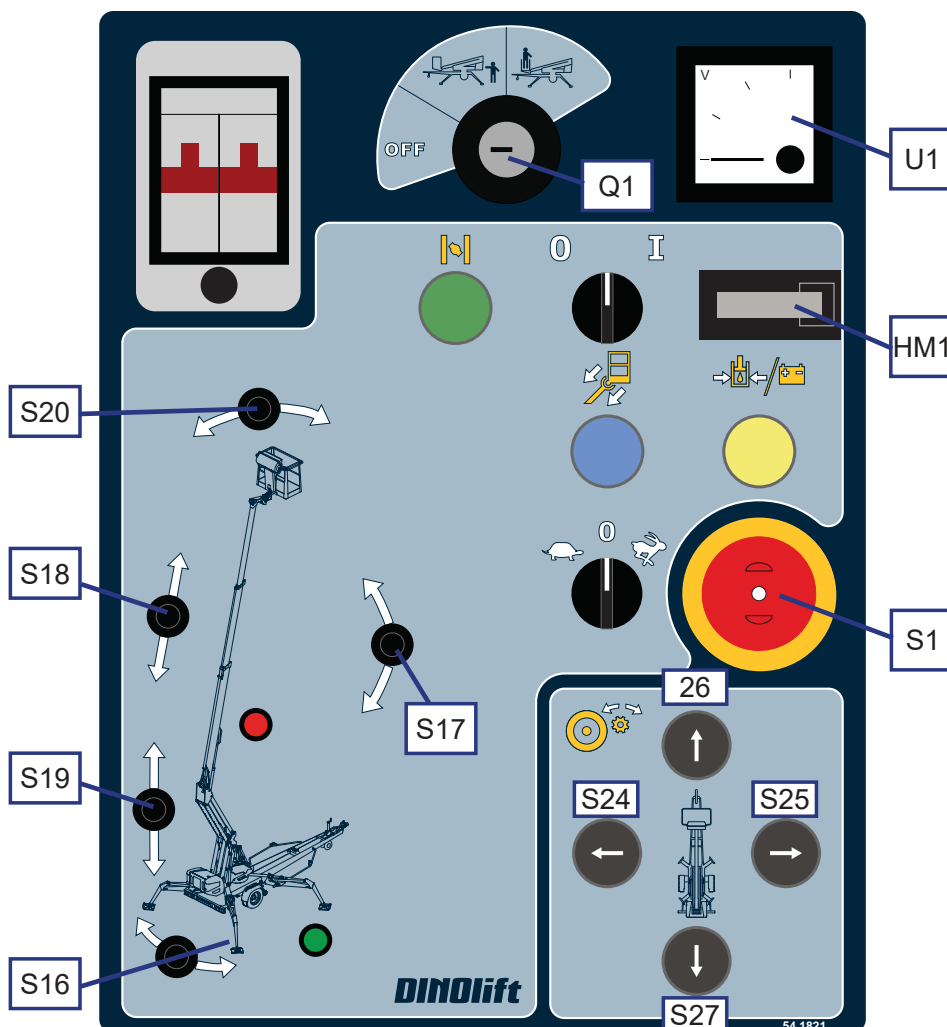

## 4.3.2. Operating controls for the outriggers

### Control levers for the outriggers

The control levers for the outrigger valve are located on the right-hand side of the lift's chassis.

1	Front outrigger, right
2	Front outrigger, left
3	Rear outrigger, left
4	Rear outrigger, right
5	Start button for the outriggers
10	Position indicator of chassis

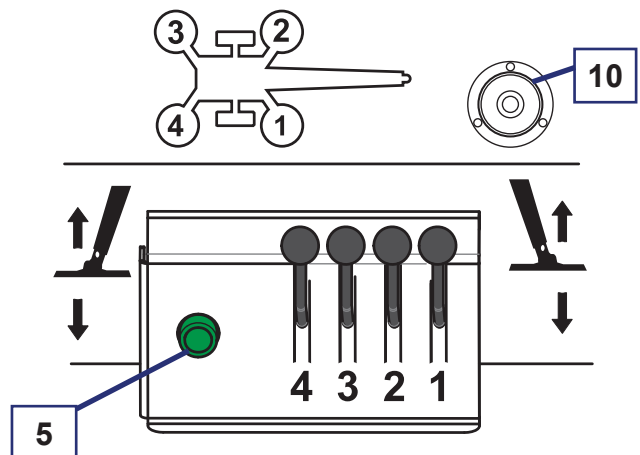

## 4.3.3. Optional controls on the chassis

### Signal lights for the outriggers

The signal lights at the outrigger control centre indicate separately the status of each outrigger limit switch.

1	Signal light, outrigger 1
2	Signal light, outrigger 2
3	Signal light, outrigger 3
4	Signal light, outrigger 4

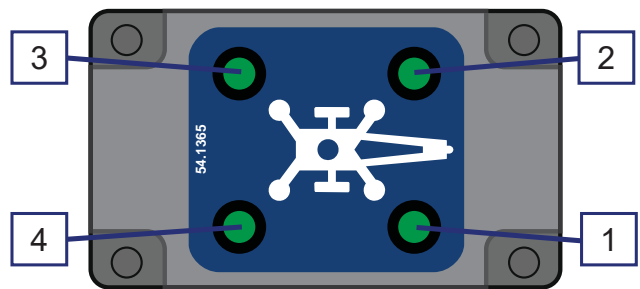

### Remote control cable for the driving device

The additional control unit is located in the toolbox on the tow-bar.

1	Activation switch for the driving control
2	Drive forward
3	Drive backward
4	Swinging to the right/left
5	Emergency stop for the driving device

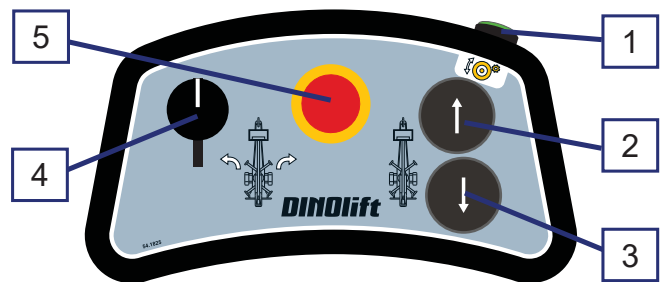

### Remote control cable for the driving device and the automatic levelling

The additional control unit is located in the toolbox on the tow-bar.

1	Operating the left driving device roller
2	Operating the right driving device roller
3	Depressing the driving rollers
4	Lever switch for automatic levelling
5-8	Levers for individual control of the outriggers
9	Signal light for the outriggers
10	Emergency stop for the driving device and outriggers

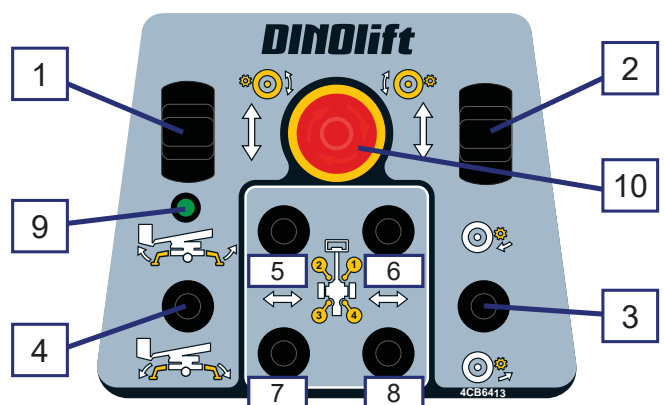

### 4.3.4. Operating controls in the platform control centre UCB

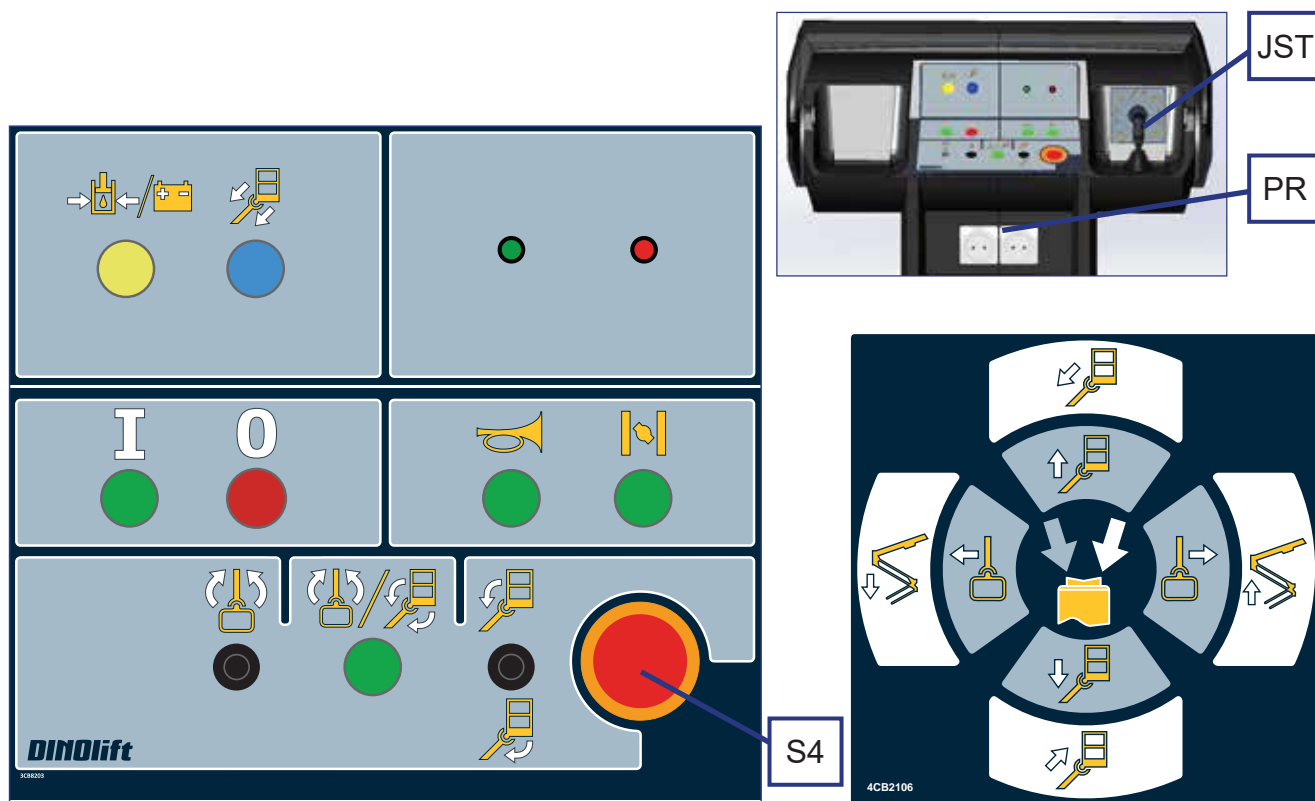

I O	Starting/stopping of the motor		Activation switch for the platform movements
	Choke		Levelling the platform
S4	Emergency stop		Turning the platform
	Starting of the emergency descent pump	JST	Control lever - Boom movements
	Retraction button for the telescope		Retracting/extending the telescope
	Sound signal		Boom up / down
	Work lights (option)		Turning the boom
PR	Socket outlets 230V/110V USB		Articulated arms down/up
	The load is within the outreach range.		
	Overloading or the load is at the outreach limit		

**Note!** The desired functions of the boom are selected by means of the activation switches at the end of the joystick. Always press the button first, and only after that, turn the handle. The safety connection prevents the movements, if the handle is turned before the button has been pushed down.

## 4.3.5. Setup with two control levers (option)

A setup with two control levers is available as an option for the platform control centre.



The left and right control levers (JST right/left) replace the normal control lever.

Press first the activation button, and only after that, move the handle. The safety connection prevents the movements, if the handle is moved before depressing the button.

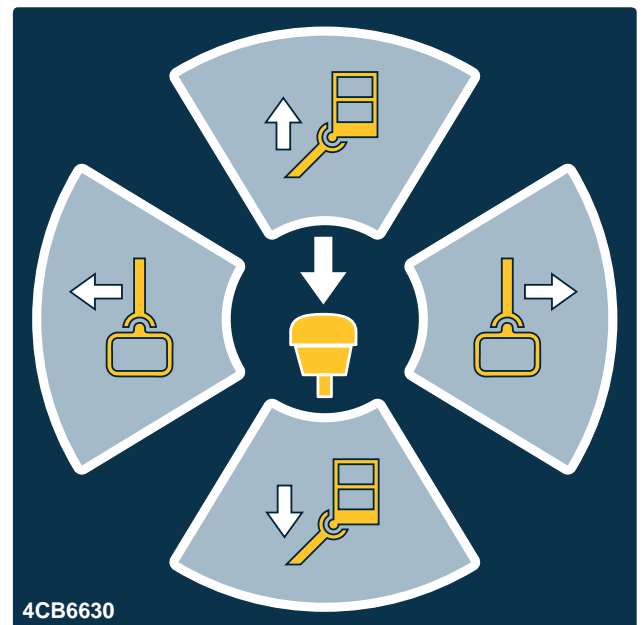
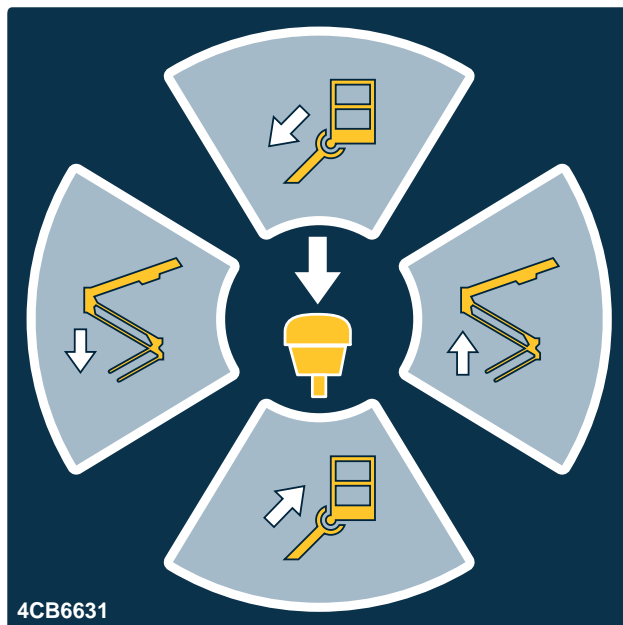

## 5. USING THE LIFT

### 5.1. STARTING UP

The operator must inspect the worksite and carry out the daily start-up routines always:

- at the beginning of each workday
- before operating the lift at a new worksite
- when the operator changes in the middle of a workday

#### 5.1.1. Worksite inspection

##### 1. General information

- Is the lift suited for the intended job?
- Is the performance of the lift sufficient for the job? (reach, loadability etc.)
- Is the position of the lift safe?
- Is the lighting on the worksite sufficient?

##### 2. Documents

- Are the Operation and Service Instructions for this lift present?
- Are inspections and servicing carried out in accordance with the instructions and have the defects affecting the safety been checked as repaired?  
(Inspection protocols)

##### 3. Operator

- Is the operator of the lift old enough?
- Has the operator received the required training?
- Is the operator in suitable condition for operating the machine? The machine must not be operated under the influence of alcohol or any other intoxicant, or if the operator's physical or mental capacity in some other respect has been impaired from normal.

##### 4. Special issues on the worksite

- Are there any additional regulations relevant to the worksite or the work?
- Are there any other potential hazards (gantry cranes, shafts, ATEX areas, closed spaces) present at the work site, which should be observed during the operation?
- Does the work area have to be marked or fenced off to prevent outsiders from moving inside the danger zone under the boom or the work platform?

##### 5. Condition of the lift

- Carry out all the daily service measures in accordance with the instructions
- Never operate the machine, if it is out of order.



## 5.1.2. Positioning the lift

1. make sure that the ground is even and hard enough to support the lift in a steady, level position

Soil material	Density	Max. ground pressure
		P kg/cm <sup>2</sup> (N/cm <sup>2</sup> )
Gravel	High density	6 (59)
	Medium density	4 (39)
	Loose	2 (20)
Sand	High density	5 (49)
	Medium density	3 (29)
	Loose	1.5 (15)
Fine sand	High density	4 (39)
	Medium density	2 (20)
	Loose	1 (10)
Sand/ mud	High density (very hard to work)	1.00 (10)
	Medium density (hard to work)	0.50 (5)
	Loose (easily worked)	0.25 (3)

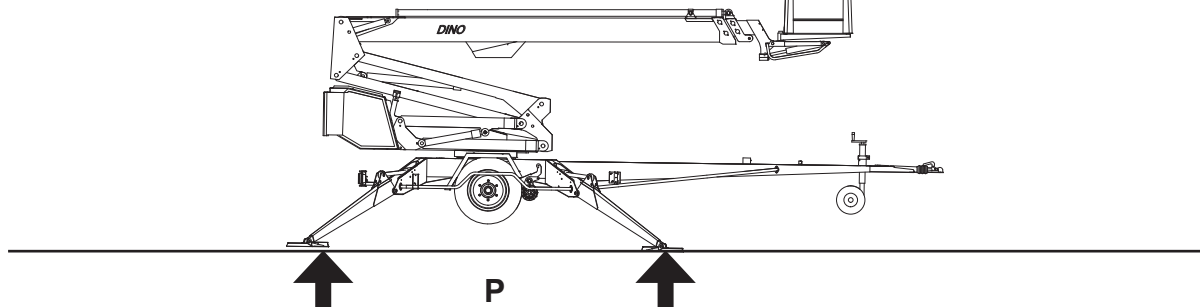

2. Check that the standing surface is free from potholes, pits or too inclined areas.
3. Check that the movement area of the outriggers and the boom, as well as the area under the outriggers, are free from obstacles, which could cause collision or turn the machine over.

 **DANGER**

**Tip over hazard!** If the ground is soft, use sufficiently large and sturdy additional plates under the support outriggers.

4. Drive or push the lift to the inspected lifting site
5. Engage the parking brake
6. Disconnect the lift from the towing vehicle

### 5.1.3. Starting up

1. If necessary, connect the power supply cable to mains current. With the electric motor at maximum load, the voltage must be 230 VAC (-10%/+6%), the frequency 50 Hz, and rating of the fuse 10A (the length of the connecting cable has some effect)
2. Switch on the main current
3. To access the operating controls, open the cover of LCB centre on the turning device.
4. Select the control centre (LCB/UCB) using the selector switch.
5. Turn on the operating voltage
  - in the LCB centre: by turning the speed selector switch
  - in the UCB centre: by pressing the activation switch at the end of the control lever

**ON**

After this, the start-stop automatics will start and stop the electric motor whenever any of the movements is activated.

The engine will stop automatically as soon as the movement stops.

NOTE! If you wish to operate the support outriggers, start the electric motor by pushing the green start button at the control centre for the outriggers. The electric motor will keep on running until the button is released.



**Ensure that the batteries remain sufficiently charged during the workday!**

#### **A ) XT: POWERED BY ELECTRIC MOTOR**

- If you want to keep the electric power unit constantly running (e.g. if the weather is cold), start the electric motor using the rotary switch. This will bypass the start-stop automatics.



## B) XT OPTION: POWERED BY COMBUSTION ENGINE, PETROL

- do not connect the power supply cable (230 VAC)
- Open the fuel cock
- As required, switch on the choke for the start by pushing the choke button.
- Start the engine via the rotary switch



If the battery is flat:

- Ensure that the key switch Q1 is in the position UCB.
- Keep the button on the bed of the petrol-driven power pack depressed, and simultaneously, pull the starter string. Pull the starter string lightly until you feel resistance, then pull briskly.
- Keep the button depressed for about 1 minute in order to recharge the battery.
- Do not allow the starter grip to snap back against the engine.
- Turn off the motor via the rotary switch after the use.



**NOTE! When you stop using the combustion engine, close the fuel cock. The fuel cock must be closed during towing of the lift.**

## C) XT OPTION: POWERED BY COMBUSTION ENGINE, DIESEL

- Do not connect the power supply cable (230 VAC)
- Start the engine via the rotary switch



Refer to the separate user manual for the diesel engine for instructions about starting up the engine, when the battery is flat.

- Turn off the motor via the rotary switch after the use.



**NOTE! To avoid damaging the electronics of the diesel engine, do not disconnect the main current while the diesel engine is running!**



**Leave the combustion engine running also between the operations, because the battery will not be recharged, unless the combustion engine is running.**

The electric timer of the lift automatically disconnects the supply voltage (12 VDC) in about 1 hour after the electric motor or the combustion engine has been turned off.

To re-activate the voltage supply, turn the speed selector switch (in LCB) or depress the activation switch at the control lever (in UCB).

### 5.1.4. Supporting the lift

1. Turn the selector switch Q1 to the position LCB – chassis control centre.
2. To activate the support outriggers, depress start button for the outriggers. The button must be kept depressed throughout the operation.
3. Lower the front support outriggers 1-2 (on the tow-bar side).
4. Lower the rear support outriggers 3-4. Be careful not to bang the tow-bar jockey wheel against the ground.
5. Level the chassis with the outriggers with the help of the level gauge. The air bubble must be located inside the inner ring.
6. The signal light (green) in the chassis control centre is illuminated, when all the outriggers are in the support position and the limit switch circuit for the outriggers is closed.

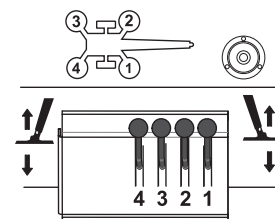

### Supporting the lift using the automatic levelling function (option)

1. Lower the outriggers from the DCB control centre via the lever switch. The automatic levelling function positions the outriggers on the ground and levels the chassis.
2. Keep the lever turned until the signal light above the switch stops flashing. If you release the lever, the operation will be interrupted and the light will go out. The levelling can be resumed by turning the lever anew.
3. If the signal light remains illuminated, the function has been successfully completed.



## NOTICE

If you have levelled the chassis of the lift ON A GRADIENT, turn the boom around carefully to ensure that the turning device does not bang against the support outriggers or other obstacles.

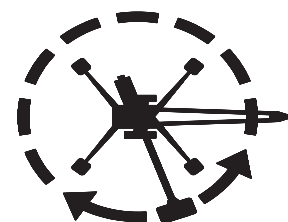
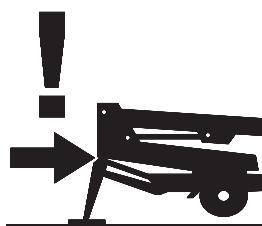

### Before using the lift, always check that:

- the chassis is in the horizontal position, in accordance with the position indicator
- the wheels are off the ground
- the outriggers are firmly supported on the ground



## DANGER

The operation is prohibited, if the lift is not properly supported and in a horizontal position.

Observe the effect of ice, possible rain and inclination of the surface on the support force (the support outriggers must not slip on the surface).

## 5.2. OPERATION



### WARNING

Carry out all the daily maintenance routines and inspections in accordance with the maintenance instructions before operating the lift. **Failure to check the safety devices may cause a serious injury or make the consequences of an accident worse.**

**All the faults, observed in the safety devices, must be repaired before the use.**

### 5.2.1. Operating the lift from the chassis control centre

1. Turn the selector switch Q1 to the position LCB – chassis control centre.
2. Select the movement speed using the speed selector switch. If the lift is operated from the control centre LCB, the movement speed cannot be continually adjusted.
3. Drive the boom and the platform using the control levers in the chassis control centre:
  - extending and retracting the telescope
  - lifting and lowering the boom
  - turning the boom
  - lifting and lowering the articulated arms
  - inclination control of the platform

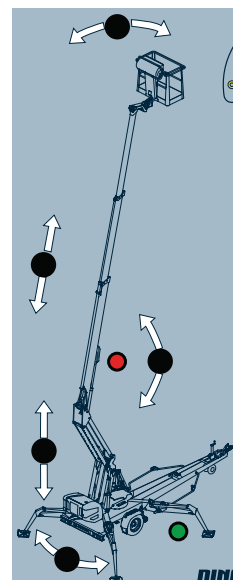

The levelling system of the platform will automatically keep the platform level during the movements. As necessary, the position can be corrected. No persons allowed on the platform during the adjustment.

The movement will stop as soon as the speed selector switch or the selector switch for the movement is released.

4. Before starting the operation, lift the platform from the tow-bar and turn it to the side so that you can lower the boom.
5. Extend the telescope as much as is necessary to ensure that stepping onto the platform is safe.

### NOTICE

Be careful not to damage the light ramps or the tow-bar jockey wheel with the work platform or the boom!



### CAUTION

Protect your hearing while using the power unit (option). Sound pressure level at the lower control centre is 94 dB(A).

### 5.2.2. Operating the lift from the platform control centre

## DANGER

**Risk of falling!** Wear a safety harness while on the platform, and fix it to the point marked for it.  
Make sure that the platform gate remains closed during the operation.

1. Turn the selector switch to the position UCB, and remove the key. Close the protective cover for the chassis control centre
2. Step onto the platform and fix the safety harness to the attachment point intended for it.
3. **Operate the boom movements using the control lever.**  
To operate the movements of the boom system, press first the rocker switch at the end of the control lever, and after that, move the control lever carefully in the desired direction of movement of the boom. The movement speed can be adjusted steplessly.  
If you move the lever before pressing the rocker switch, the action will be deterred.

	Activation button – Operating direction of the lever	Movement	Symbol
	JSL - up/down	Boom up/down	
	JSL - to the left / right	Turning the boom clockwise/ counter-clockwise	
	JSR - up/down	Retracting/extending the telescope	
	JSR - to the left / right	Articulated arms down/up	
Always try to keep the boom short during the lifting and lowering movements.			

4. **Operate the platform movements using the lever switches.**
- |   |  |
|---|--|
| Push the activation switch for the platform movements, and keep it depressed throughout the movement. |  |
| Select the movement and its direction using the lever switches  |  |

As required, see the point "Operating controls in the platform control centre" for more information.

## WARNING

**Never add load onto the platform, while the red overload light is illuminated. Tip over hazard!** Measures to be taken after an event of overloading:  
Retract the platform to inside the operating range of the RK4 by pressing the "telescope in" button (the green light will be illuminated). After this, the lift may be operated normally.

5. With the boom slightly lifted and the telescope extended, make sure that the platform does not lower by itself while the operating controls are not being used.
6. Drive the platform to the work object.



## CAUTION

The lift itself, the buildings around it and other obstructions constitute a risk of getting squeezed. Hands and legs must be kept inside the work platform while the platform is moving. Also beware of any obstacles above the platform.

### **IF THE SAFETY DEVICES OR THE EMERGENCY DESCENT SYSTEM ARE NOT WORKING, HAVE THEM REPAIRED BEFORE OPERATING THE LIFT.**

The platform movements can be operated with continually adjustable speed from the platform control centre (not from the chassis control centre). Only one movement can be operated at a time. If several control levers are operated simultaneously, only the movement with the least resistance will operate.

#### **Observe when lifting the platform**

- the operating range of the platform depends on the load (see “Technical Data”) and is monitored by the safety limit switches RK4 and RK5 located under the protective cover
- The limit switches must not be adjusted or modified. The inspection and adjustment may only be carried out by an authorized serviceman.

#### **Working a long time in the same position**

- If the weather is warm, and the platform is kept for a longer period of time in the same position, it is not necessary to let the engine run continuously.
- if the weather is cold, keep the hydraulic oil warm by allowing the engine to run
- ensure that the battery remains sufficiently charged even during long-term work in the same position As necessary, use either the mains or the power pack to maintain the sufficient state of charge of the battery.
- check the stability and condition of the base regularly during the operation, taking into account the weather and ground conditions
- the electric timer of the lift automatically disconnects the supply voltage (12 VDC) in about 1 hour after the electric motor or the combustion engine has been turned off.
- Re-activate the power supply by pressing the start button either in the chassis control centre or in the platform control centre.

#### **When moving the platform, remember the following**

- beware of high voltage power lines
- do not touch open electric wires
- do not throw objects from the platform
- do not damage the lift
- do not damage other devices



## DANGER

**It is strictly prohibited to take additional load in the upper position.**

Do not exceed the lateral force (400N), or load the platform in the vertical direction more than allowed.

### Lowering the platform to the transport position

Always retract the telescope completely and turn the platform perpendicular to the boom before lowering the boom onto the transport support.

## NOTICE

Do not damage the handbrake lever or the tow-bar jockey wheel while lowering the platform to the transport position!

### When leaving the lift

- drive the lift to a safe position, preferably to the transport position
- switch off the power unit
- prevent unauthorized use of the lift by locking the control centre cover



### 5.2.3. Special instructions for winter use

**The lowest allowed operating temperature of the lift is -20 °C**

In cold conditions, carry out the following special actions in addition to the normal start-up procedure

1. Let the power pack run for a few minutes before starting the movements.
2. To ensure the proper operation of the valves, do a few warm-up movements to change warm oil in the cylinders.
3. Check that the limit switches and the emergency descent devices are operational and clean (from dirt, snow, ice, etc.).
4. Protect the control centre and the platform from snow and ice whenever they are not in use.
5. Ensure that the batteries are charged. Flat batteries freeze easily.



**Always keep the lift free from dirt, snow etc.**

### 5.2.4. Ending the work

At the end of the workday:

1. Retract the telescopic boom fully.
2. Check that the platform is perpendicular to the boom.
3. Lower the boom/platform onto the support on the tow-bar. The limit switch on the transport support prevents the operation of the support outriggers if the platform is not down.
4. Close the control centre cover on the work platform.
5. Turn the selector switch to position OFF, and turn off the main switch.
6. If you want to recharge the battery, leave the mains cable connected; otherwise disconnect the lift from the mains supply.
7. Make sure that the covers are locked.

## **NOTICE**

To ensure proper operation and long service life of the batteries, it is recommended to always recharge them at the end of each workday, even though there was still plenty of charge left. Storing the batteries flat shortens their service life, and flat batteries also freeze easily.

### 5.3. TRANSFERRING THE LIFT

The lift can be transferred by towing or using its own driving device.



**The lift may only be moved in the transport position. No persons or load are allowed on the platform during the transportation.**

#### 5.3.1. Preparing the lift for transport

During transfer, the lift must always be in the transport position.

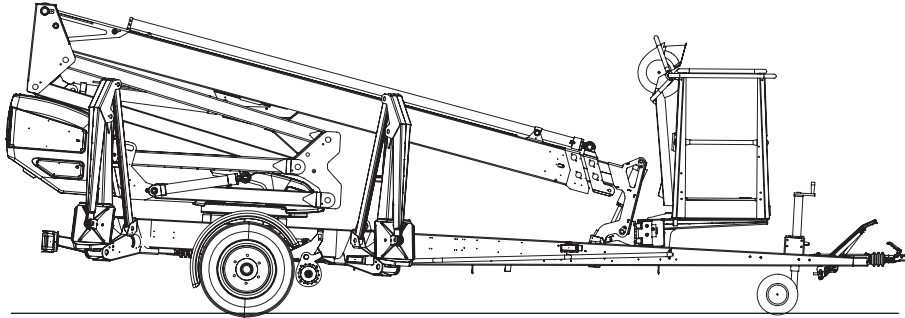

Prepare the lift for the transfer as follows:

1. Retract the telescopic boom fully.
2. Check that the platform is perpendicular to the boom.
3. Lower the boom/platform onto the support on the tow-bar. The limit switch on the transport support prevents the operation of the support outriggers if the platform is not down.
4. Close the control centre cover on the work platform.
5. Turn the selector switch to the position (1) – chassis control centre.
6. Lift the support outriggers.  
Lift first the rear support outriggers (do not damage the rear lights), and then the front support outriggers (do not damage the jockey wheel).
7. Make sure that the covers are locked.

If you intend to tow the lift:

8. Apply the parking brake.
9. Make sure that the driving device is disconnected.
10. Turn the selector switch to position OFF and disconnect the lift from the power supply.

## 5.3.2. Using the driving device

The hydraulic driving device is intended for moving the lift within the work area if the towing vehicle cannot be used.



**During transfer in rough terrain, always try to position yourself higher than the machine.**

1. Turn the selector switch Q1 to the position "chassis control centre".
2. Make sure that the platform is in the transport position and the outriggers have been lifted to the upper position.
3. Make sure that the mains cable is long enough to cover the whole travel distance – or that the cable has been disconnected.
4. Switch the driving device to the drive position.
5. Release the handbrake.
6. Turn the speed selector to activate the movement.  
The switch must be kept turned throughout the operation.  
The driving device operates at a constant speed.
7. Select the driving direction via the pushbuttons.
8. Steer the lift via the pushbuttons during driving.

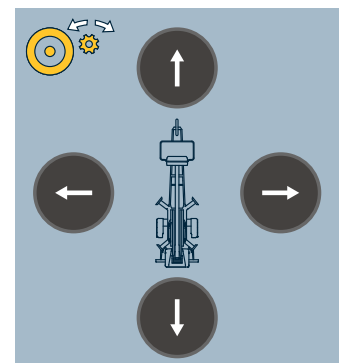
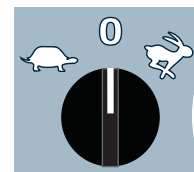
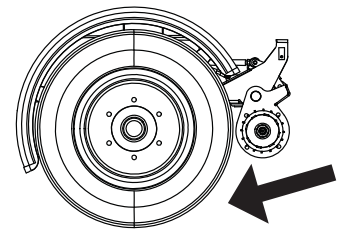

## CAUTION

**Do not drive the jockey wheel into obstacles or potholes.** If one of the wheels bumps into an obstacle, the lift may turn abruptly.

After the driving:

- Apply the handbrake.
- Disconnect the driving device from the tyre.

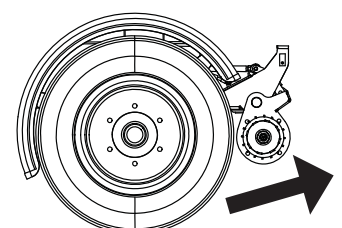

## NOTICE

### Be careful not to damage the jockey wheel tube by extending it too much.

When moving the lift using the driving device, a suitable length for the jockey wheel's stem can be achieved by adjusting the gap between the lower surface of the tow-bar/brake rod and the wheel to 1-3 cm. Then the wheel may turn freely.

### On a slope:

1. When driving on a slope, the tow-bar must always point towards the descent. Never drive with the driving device with the tow-bar pointing towards the ascent.
2. Always place chocks under the wheels before disconnecting the device from the towing vehicle.
3. Always apply the handbrake before disconnecting the lift from the towing vehicle.
4. Only use the handbrake as a parking brake or for emergency stopping.
5. When transferring the lift using the driving device:
  - take care not to allow the wheel to roll over your foot
  - look out for sudden sideways movements of the tow-bar
  - be careful not to cause danger to other people and the environment
6. Do not move the device on a slope using only hand-power. You may lose control over it and cause an injury.
7. Never park a vehicle combination on a slope.
 

Never leave the lift on a slope being supported only by the self-braking action of the driving device.

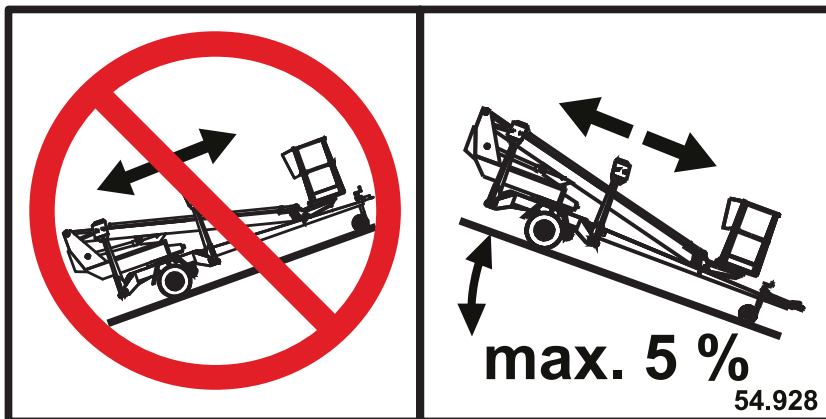

Do not drive downhill with the driving device, if the inclination of the surface is more than 5 per cent, (corresponding to a descent of 0.5 m over a distance of 10 m). If the gradient of the surface is greater than this, you may lose control of the device.

### 5.3.3. Towing the lift

Connecting to the towing vehicle

1. Lift up and push forward (in the driving direction) the handle of the ball-coupling. Now the ball-coupling is released.
2. Press the ball-coupling onto the towball using only a little force. The connection and locking take place automatically.



**Always make sure, after the connection, that the ball-coupling is properly locked.**

3. Connect the emergency stop wires and light plug to the vehicle. Check the cable for chafing and proper operation of the wires.
4. Check the operation of the lights.
5. Carefully release the parking brake and make sure that its locking is in order and that its handle stays in the lower position.
6. Lift up the jockey wheel to the transport position.



**Clean and lubricate the ball-coupling regularly.**

In particular, if you are parking or disconnecting the lift from the towing vehicle on a slope, apply the parking brake as firmly as possible. After having applied the parking brake, push the lift backward to make the reverse automatics release the brake shoes. The spring cylinder pulls the parking brake tighter, and the brakes of the vehicle will again be properly engaged.

Adjust the brakes according to the service instructions.

Place chocks under the wheels as an additional precaution.

## NOTICE

Observe the national traffic regulations, the local and worksite-specific instructions, as well as the instructions concerning the towing vehicle.

### **Always ensure before towing:**

- transport position of the outriggers
- locking of the ball-coupling
- operation of the lights, connection of the cable
- that the parking brake is disengaged
- condition and pressure of the tyres. The correct pressure ratings are marked both on the tyres and on the jockey wheel bracket.
- attachment of the safety wire
- locking of the brakes after the transportation
- locking of the jockey wheel in its upper position
- that the driving device is disconnected from the wheel
- that there is no load on the platform



**Always place chocks under the wheels, before disconnecting the lift from the car.**

### 5.3.4. Tying down

If the lift is transported by other means than towing, it must be tied down at the marked points for the transport. The tying points are symmetrically located on either side of the lift.

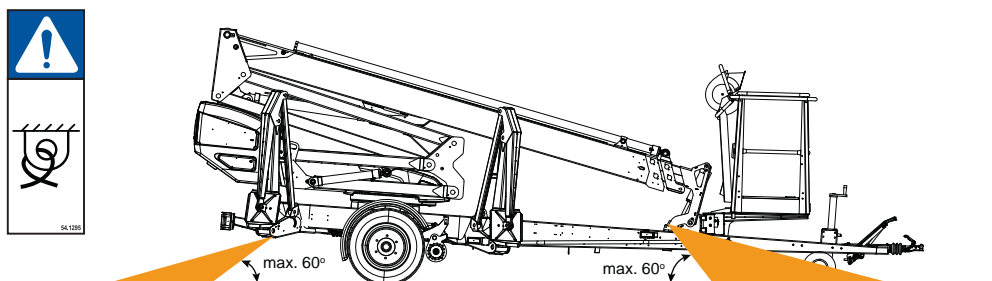

## CAUTION

**Risk of falling!** Tie down the lift to the vehicle for the transport. The chassis of the lift is fitted with specific, marked lugs for tying. To avoid structural damage, use only the marked tying points.

## 5.3.5. Lifting the device

The device can be lifted using the lugs shown in the picture. The lifting lugs are located symmetrically on both sides of the lift.

During lifting the aerial work platform must be in the transport position. Remove all loose material from the top of the frame structures and the work platform before starting the lifting. Use for lifting a suitable crane with sufficient capacity and relevant accessories. Check the weight of the lift in the technical specifications.



**Be careful not to damage the unit during the lifting operation.**

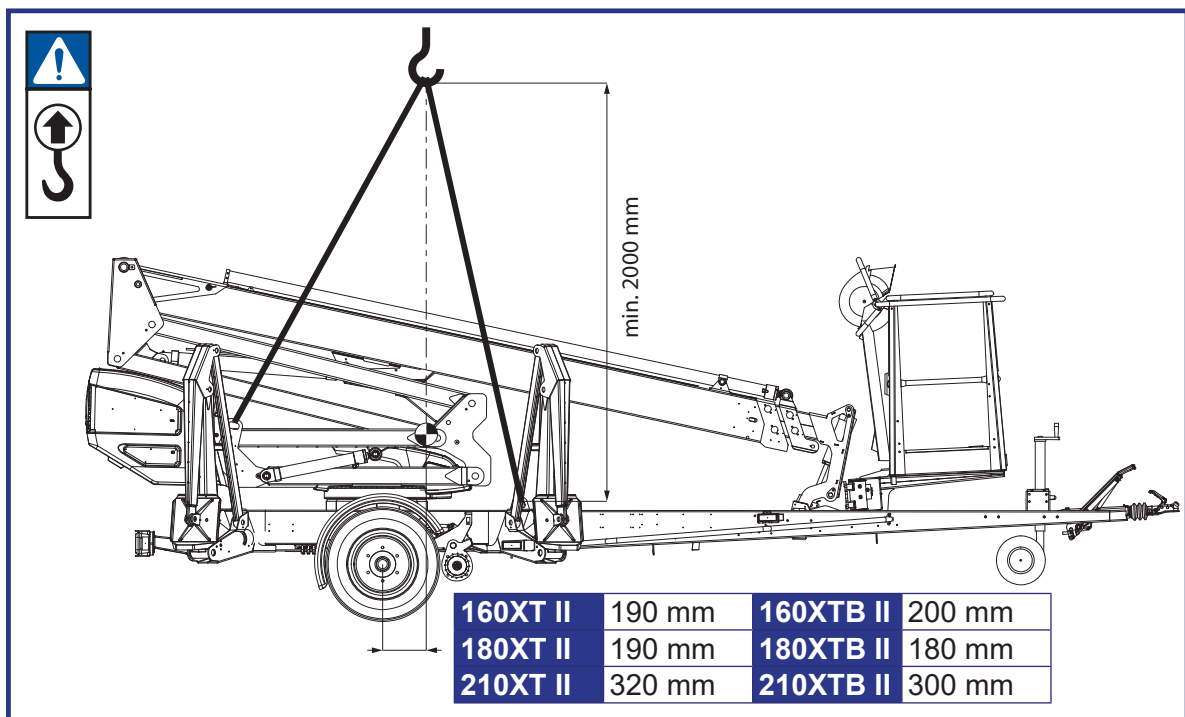

## 5.4. LONG-TERM STORAGE

Clean the machine carefully, lubricate it and apply protective grease to it before putting it into storage for a longer period of time (see point "Lubrication plan"). Repeat the cleaning and lubrication procedures when you resume the operation.

### NOTICE

If you leave the lift standing for a longer period of time, for example over the winter, we recommend propping it up to release any load from the wheels.

The periodic inspections must be executed following the steps described in the instructions.

## 6. DINO SKY RACK (OPTION)

Dino Sky Rack is a DINO accessory intended for lifting of panels of sheet material and pipes.

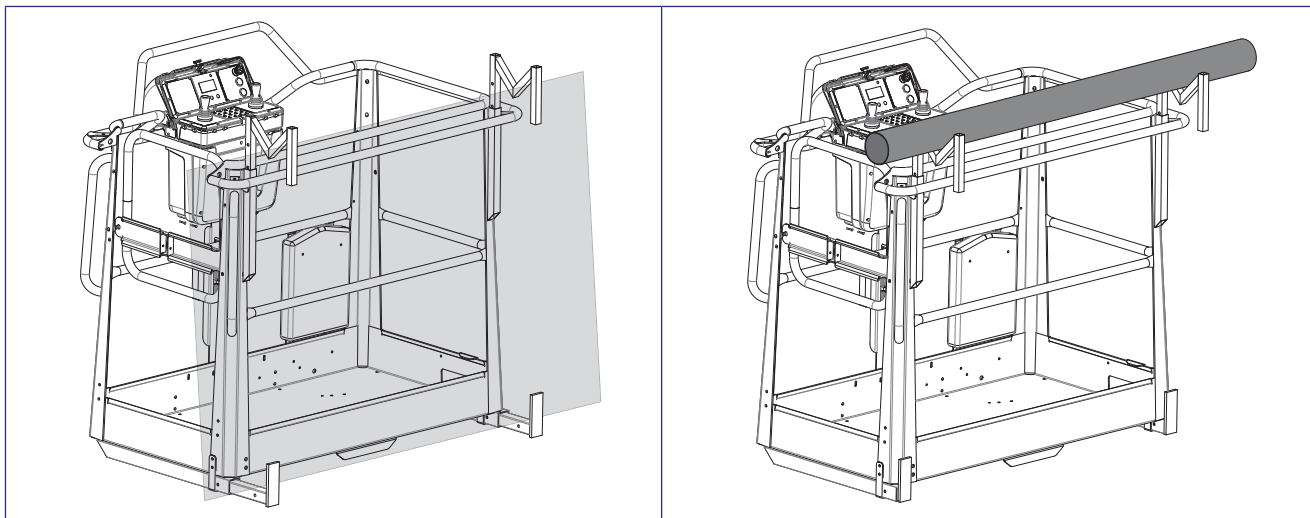

### Technical specifications

	160 XT/XTB , 180XT/XTB , 210XT/XTB 280RXT
Max number of persons on platform	1
Max. allowed load on rack	100 kg
Max. panel area	3 m <sup>2</sup>
Max. panel height	1250 mm
Max. wind speed during operation	7 m/s
Weight of the Sky Rack	6 kg

#### Before operation:

- Check, that the upper and lower supports are not bent or otherwise damaged.
- Check that the locking pins are in place in all supports.

#### Lifting panels:

1. Place the lower supports to their desired positions. Secure the supports with locking pins.
2. Load the panel on the rack
  - center the load on the platform
  - place it on at least two of the lower supports
1. Turn the upper supports outside of the platform railing. Place the supports on desired height so that the panel can not tip over. Secure all supports with locking pins.
2. If necessary, secure the panel with straps so that it can not fall off during lifting.

Lock upper and lower supports in their shortest position when the rack is not in use.





## DANGER

### Tip over hazard!

The panels will increase the area exposed to wind and decrease the stability of the machine. Follow all instructions on maximum panel size and operating conditions.

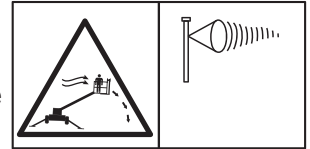

### Lifting pipes:

1. Place the lower supports to the shortest position. Secure the supports with locking pins.
2. Turn the upper supports outside of the platform railing and place the supports on desired height. Secure the supports with locking pins.
3. Load the pipe on the rack
  - center the load on the platform
  - place it on at least two of the upper supports
4. Secure the pipe with straps so that it can not fall off during lifting

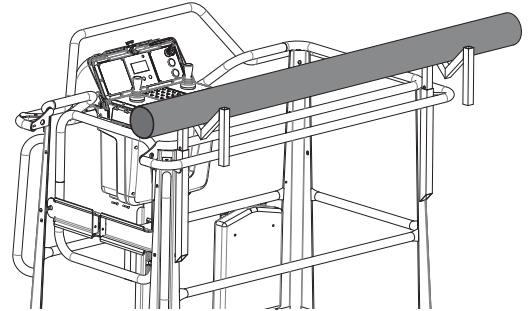

## WARNING

The weight of the Sky Rack assembly, load on the rack and load on the platform must not exceed the maximum allowed load on the platform of the machine!

### When the SkyRack is not in use:

1. Turn the upper supports between the handrails.
2. Place the upper supports in the lowest position. Secure the supports with locking pins.
3. Place the lower supports to the shortest position. Secure the supports with locking pins.

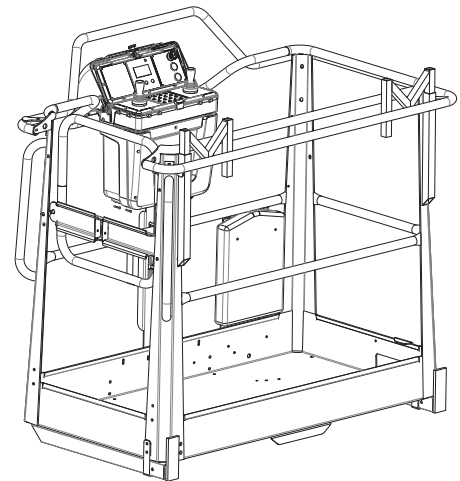

### Maintenance

- Check supports for bent, crushed or missing parts
- Replace damaged or missing parts
- Replave illegible or missing decals

## 6.1. IN CASE OF EMERGENCY

### 6.1.1. When at risk of losing the stability

Reduced stability can be caused by a fault in the lift, the wind or other lateral force, collapse of the standing base or negligence in providing sufficient support. In most cases one sign of reduced stability is the inclination of the lift.



1. If there is time, try to find out the reason for the reduced stability and the direction of its effect. Warn other people on the worksite using the alarm signal.



2. If possible, reduce the load from the platform in a safe manner.

3. Reduce the outreach to the side by retracting the telescopic boom using the emergency descent system. Avoid abrupt movements.

4. Turn the boom away from the danger zone, i.e. to a position where the stability of the lift is normal.

5. Lower the boom.

If the stability has been lost as a result of a fault in the lift, repair such a fault immediately.



**Do not use the lift until the fault has been repaired and the condition of the lift has been verified.**

### 6.1.2. In case of overloading



1. If there is time, try to find out the reason for the reduced stability and the direction of its effect. Warn other people on the worksite using the alarm signal.

2. If possible, reduce the load from the platform in a safe manner.



3. Use the “telescope in” pushbutton, if the set value of the RK5 has been exceeded.

4. The green light will illuminate as soon as the overloading situation is reset. After this, the machine may be operated normally.

### 6.1.3. In case of power failure

As a precaution against power failure or other malfunction of energy supply, the lift is equipped with a battery operated emergency descent system.



1. Start the emergency descent system via the pushbutton. The emergency descent system is operational only when the pushbutton is being depressed.



2. Reduce the outreach to the side by retracting the telescopic boom using the emergency descent system. Avoid abrupt movements.

3. Using the emergency descent, retract first the telescope completely, then lower the boom. Finally, turn the boom.

4. Establish the reason why the energy supply was interrupted.

**Note!** The emergency descent system can also be used for raising the support outriggers to the transport position

Always check the condition of the battery for the emergency descent system before putting the lift into operation.

(See point “Operation of the safety devices”)

### **Setup of the emergency descent system**

- 12 V, 44 Ah
- recharger
- hydraulic unit 12 VDC

### **The hydraulic unit comprises**

- pressure relief valve, set value 16 MPa (160 bar)
- check valve
- direct current motor of 800 W

### **6.1.4. In case of malfunction, when even the emergency descent system is not operational**

If not even the emergency system is working, try to warn other personnel present on the site or call for more help. When help arrives, try to

- restore the power supply required for normal operation
- make the emergency descent system operational by, for example, changing the battery
- resume the lift's normal operation by other means

Always check the condition of the emergency descent system battery before putting the lift into operation (see point “Operating from the chassis control centre”).

## 7. INSTRUCTIONS FOR FAULT-FINDING

FAULT	REMEDY
-------	--------

### 1. The electric motor does not start from its start button although the selector switch 1 is in the position that enables operation from either the chassis or the platform control centre

The emergency stop button has jammed in the lower position.	Pull up the button and re-start the motor from the start button.
Fuse F1 has blown.	Replace the fuse (10A).
No mains supply (230 VAC) to the selector switch.	Check the extension cords, possible distribution boards and fuses.
Fault current safety switch has tripped.	Reset the fault current safety switch.
No direct-current supply (12VDC).	Main switch has been turned off, turn on the switch.

### 2. No power supply to the lift, although the main switch is on and the selector switch is in the position that enables operation from either the chassis or the platform control centre

Power supply has not been activated.	Press the start button to activate the power supply.
Battery is flat.	Recharge the battery.

### 3. Power unit does not start

Battery is flat.	Recharge the battery.
The mains cable is plugged.	Disconnect the plug from the mains.
No supply of direct-current (12VDC), because the main switch is disengaged.	Switch on the main switch.

### 4. Power unit cranks but does not start

Fuel tank is empty.	Fill the fuel tank.
Choke is off.	Press the choke button (cold engine). 
Throttle lever is in idling position.	Increase the engine revolutions.

### 6. None of the boom movements is operational, although the electric motor is running and the selector switch is in the correct position (operation from the chassis control centre or the platform control centre)

The lift has been overloaded.	Reduce the platform load or	
	Retract the telescope until the platform returns inside its operating range (the green light in the platform control centre is illuminated).	

FAULT	REMEDY
-------	--------

## 7. Outriggers do not move

The boom is not resting on the transport support.	Drive the boom onto the transport support.
The selector switch is in the wrong position.	Turn the selector switch to the correct position.
Limit switch on the boom support has not closed.	Drive the boom onto the transport support.

## 8. Malfunctions of platform movements – only one of the movements can be operated

Lifting and lowering of the boom and the extension of the telescope are not operational, the red light is illuminated on the platform and in the chassis control centre, and the buzzer is audible.	The boom has been overloaded; retract the telescope and retry the operation (automatic reset).
---	--

## 18. Driving device is not operational, although the selector switch is in the correct position

Boom is not resting on the transport support.	Drive the boom onto the support.
The emergency stop button of the cable-operated remote control for the driving device has been depressed.	Release the emergency stop button.

## 24. Wheel brakes overheat

Parking brake not completely released.	Release the parking brake completely.
--	---------------------------------------

## 25. Ball-coupling is not locked

Inner parts of the ball-coupling dirty.	Clean and lubricate.
Tow-ball of the towing vehicle too large.	Make sure that the towing ball of the towing vehicle is the right size for the lift's tow hitch.  According to DIN74058, the diameter of the ball must be max. 50 mm and min. 49.5 mm.

**In all other fault conditions, the lift must be submitted to a qualified DINO service provider.**

### To avoid malfunctions

- Follow the operating instructions
- Beware of dangerous situations, which can damage the lift
- Keep the lift clean and protect it against moisture

**NOTES**

**NOTES**

## 8. MAINTENANCE SCHEDULE

Maint.	Schedule	Person responsible	Reference
A	Daily	Operator	Operating instructions
B	1 month / 100 hours*	Competent person who is familiar with the lift	Maintenance instructions
C	6 months / 400 hours*	Competent person who is familiar with the lift	Maintenance instructions
D	Annually / 800 hours*	Skilled technician who is well familiar with the structure and operation of the lift	Maintenance instructions
E	As needed	Skilled technician who is well familiar with the structure and operation of the lift	Maintenance instructions

\* Service must be performed every indicated month or operating hour interval, whichever comes first.

### NOTICE

In addition to the daily maintenance routines according to the maintenance schedule, every operator is obliged to perform a site-specific worksite inspection.

T = Check (general/visual checking of condition).

P = Thorough Inspection. To be performed following the procedure, described in the separate maintenance instructions.

V = Lubricate

S = Carry out replacements and repairs in accordance with this point

Always lubricate the lift and apply a protective grease film immediately after the washing.

The lift must be subjected to an extraordinary inspection always after an exceptional event. An event is exceptional, for example, if the lift has been damaged so severely, that its strength or operational safety may have been endangered. Consult the maintenance manual for more detailed instructions.

### NOTICE

If the lift is equipped with a petrol-driven or a diesel power pack, then in addition to the normal maintenance routines must also be carried out the service measures in accordance with the power pack's manual.

### NOTICE

Under demanding conditions where moist, corrosive substances or corrosive climate may speed up the deterioration of the structures and induce malfunctions, the maintenance intervals must be shortened, or the influence of corrosion and malfunctions must be reduced by using appropriate protective agents.



Maintenance item		A	B	C	D	E
1	Condition of chassis structures, boom and work platform	T	T	T	P	
2	Bearings of the overload protection device joint		V	T/V	T/V	
3	Bearings of outriggers and outrigger cylinders		V	T/V	P/V	
4	Bearings of outrigger footplates and moving parts of outrigger limit switch system		V	T/V	P/V	
5	Bearings of boom and articulated arms		V	T/V	T/V	
6	Bearings of the platform		V	T/V	T/V	
7	Bearings of the levelling cylinders		V	T/V	T/V	
8	Bearings of the lifting cylinder		V	T/V	T/V	
9	Sliding surfaces / rolls of the telescope		T/V	T/V	T/V	
10	Bearings of the telescope cylinder			T/V	T/V	
11	Condition of cylinders				P	
12	Flyer-chain			V	P/V	
13	Slide pads and sliding pad clearances		T	T	T	
14	Turning device			V	P/V	
15	Electro-hydraulic rotating adaptor				T	
16	Tyres and tyre pressures	T	T	P	P	
17	Coupling / overrun device		T	V	P/V	
18	Jockey wheel slide and threads				P/V	
19	Brakes			T	T	
20	Axles and suspension				P	
21	Driving device		T	V	P	
22	Lights	T	T	T	P	
23	Hydraulic oil	T	T	T	S	
24	Hydraulic hoses, pipes and fittings	T	T	T	P	
25	Condition and attachment of battery, electrical devices and wiring		T	T	P	
26	Hydraulic pressure				P	
27	Condition of safety limit switches				T	
28	Operation of safety limit switches	T	T	T	P	
29	Operation of overload protection device			T	P	S
30	Load holding and load regulation valves			T	T	
31	Platform levelling system		T	T	T	
32	Platform control devices	T			P	
33	Emergency descend, emergency stop and sound signal	T	T	T	T	
34	Labels, machine plates and instructions	T	T	T	T	
35	Test loading				P	
36	Corrosion protection				T	S
37	Movement speed adjustment					S
38	Special inspection					S

## 8.1. SCHEDULE FOR INSPECTIONS REQUIRED BY THE AUTHORITIES

**Inspections must be performed in accordance with local, state or federal regulations, legislation, directives, standards.** The manufacturer recommends following inspections, as required by local authorities in platforms country of origin.

A pre-use inspection must be done before taking the platform to use for the first time and before first start-up after major repairs and alterations.

A thorough inspection and a test loading of the lift must be carried out at least once every twelve (12) months.

The platform should undergo a major inspection within ten (10) years after having been originally put into service. A major inspection includes non-destructive testing and inspection while dis-assembled.

A special inspection should be done if the platform has been exposed to exceptional circumstances which may have affected the structural integrity of critical components.

The inspections should be carried out on regular basis throughout the service life of the lift.

If the lift is used under extreme conditions, intervals between the inspections shall be reduced.

The overall operating condition of the lift as well as the condition of the safety-related control devices shall be established in the regular inspections. Particular attention shall be paid to changes which affect the operational safety.

During inspections the notifications given in previous inspections, practical experience from use and information on performed repairs should be taken into account and can be implemented for better safety.

Major and special inspections shall be carried out by a competent person or competent body, who is familiar with the operation and structure of the lift. The competent person should periodically update their knowledge and be able to demonstrate their competency if so required.

A report should be made of the inspections and the reports should be kept with the unit stored in the space reserved for it.

The report should include

- information about the inspection
- data of repair welds (date, what was repaired and repaired by whom)

When the lift is ready for operation after annual inspection, the date of inspection shall be marked on the inspection plate affixed to the lift.

### **NOTICE**

**Check the regulations for the inspections and the competence of the inspector with the local authorities.**

## 8.2. LUBRICATION PLAN

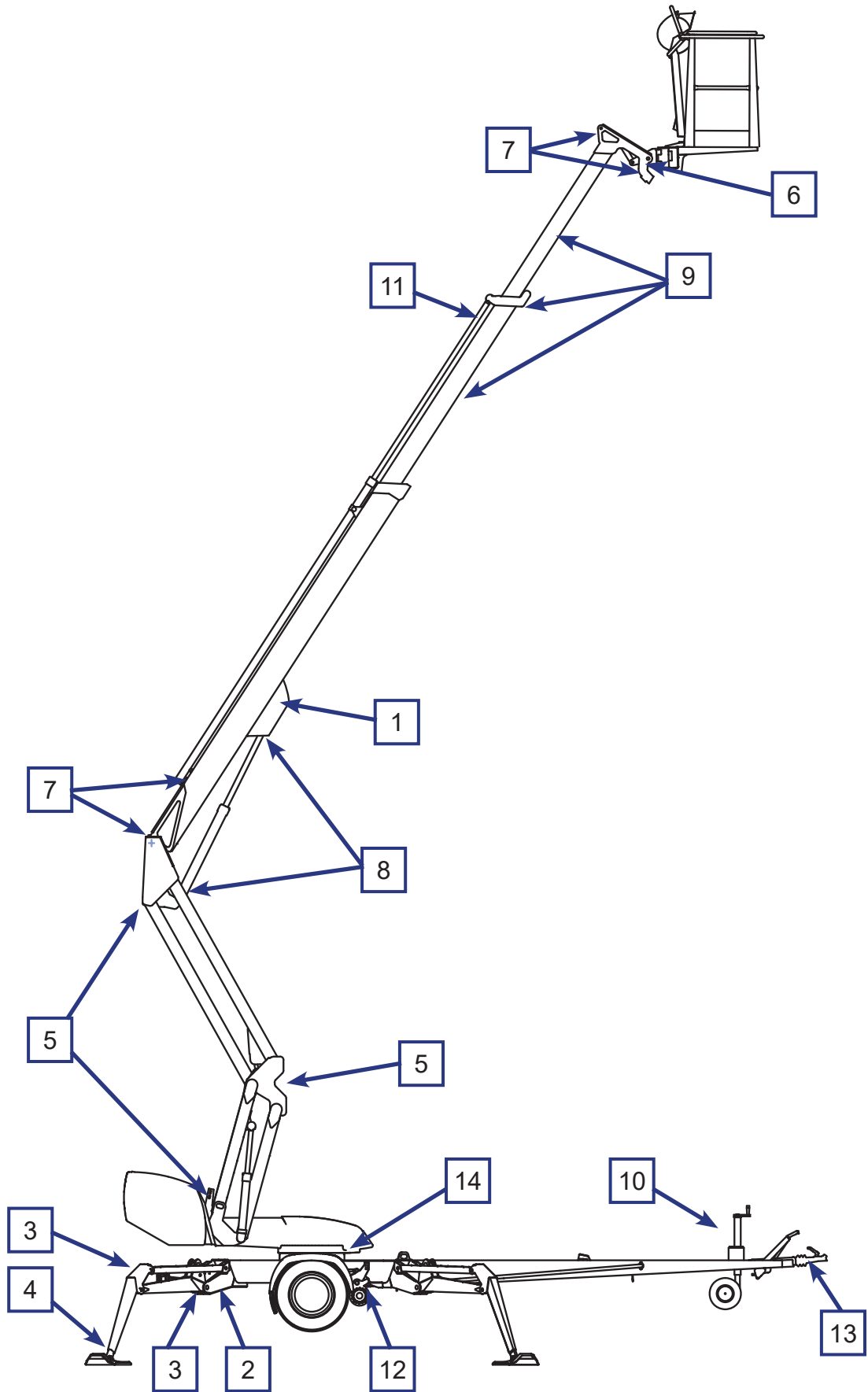

## 9. ROUTINE MAINTENANCE DURING OPERATION

The maintenance operations, that are the responsibility of the operator, are described in this chapter.

The more demanding maintenance operations that require special skills, special tools or specific measurements and adjustment values are instructed in the separate Maintenance Instructions. In such maintenance and repair cases, the operator shall contact an authorized service provider, the distributor or the manufacturer.

Make sure that all the service and maintenance procedures of the lift are performed in time and according to the given instructions.



### WARNING

Any such faults, observed during operation or periodic service, which affect the operational safety of the unit, must be repaired before the lift is used next time.

Keep the lift clean. Clean the lift especially carefully before services and inspections. Impurities may cause serious problems, for example, in the hydraulic system.

Use original spare parts and consumables. Consult the spare parts list for more detailed information about the parts.

#### **The first service after 20 hours of operation**

- change the pressure filter element
- adjust the brakes according to the instructions (see point “Wheel brakes and bearings”)
- check the wheel bolts for tightness after about 100 km of driving

**If the lift is operated under demanding conditions (in exceptionally humid or dusty environment, corrosive climate, etc.) the intervals between the oil changes and the other inspections shall be shortened to meet the prevailing conditions in order to maintain the operational safety and reliability of the lift.**

**The timely performance of the periodic servicing and the inspections is absolutely mandatory, because neglecting them may impair the operational safety of the lift.**

**The guarantee will not remain valid, if the servicing and the periodic inspections are not performed.**

## 9.1. INSTRUCTIONS FOR DAILY MAINTENANCE AND INSPECTIONS

### 9.1.1. Check the condition of chassis, the boom and the work platform

Check visually the condition of the access routes, the work platform, the platform gate and the handrails.

Check visually the condition of the boom and the frame structures.

### 9.1.2. Check the tyres and tyre pressure

Check visually that the tyres are duly inflated, and do not show any damage.

### 9.1.3. Check the lights

Check the condition of all the warning and signal lights as well as the road traffic lights of the trailer.

### 9.1.4. Check the hydraulic oil level

Check the hydraulic oil level with the platform in the transport position.  
If necessary, top up hydraulic oil in accordance with the scale on the tank.

The hydraulic oil tank is located under a cover on the right-hand side of the lift.

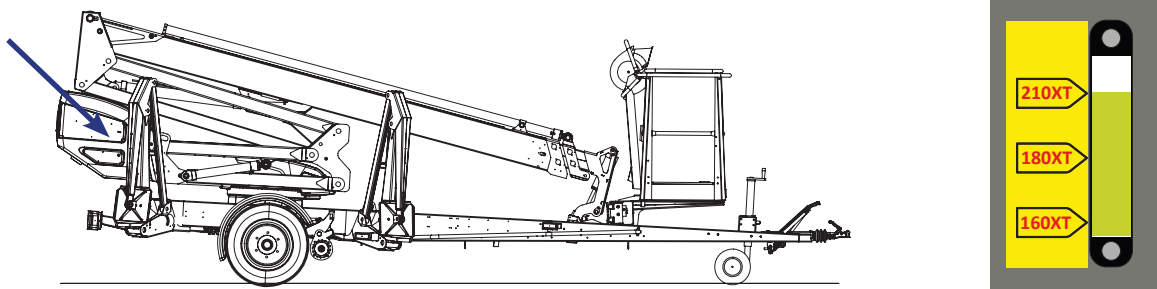

At the same time, check in the level eye of the oil tank that the oil is looking clean and normal (no excess foam etc.).

### 9.1.5. Check the hydraulic hoses, pipes and connectors

Check visually the hydraulic hoses, pipes and connections.  
Make sure that there are no visible oil leaks.

Replace any externally damaged hoses and clashed pipes or fittings.

### 9.1.6. Check the operation of the safety limit switches

Test the operation of the safety limit switches that prevent the movements of the boom and the outriggers as follows:

1. The lift is in the transport position with the outriggers in the upper position, and the driving device connected.
2. Lift the boom via the controls in the chassis control centre.  
**The boom must not operate in any position of the selector switch.**
3. Lower the outriggers to the operating position of the lift
4. Using the controls in the chassis control centre, lift the boom so much that it raises from the support
5. Drive the outriggers.  
**The outriggers must not operate in any position of the selector switch.**

### 9.1.7. Check the operation of the emergency descent, the emergency stop and the sound signal

Test the operation of the emergency stop, the emergency descent system and the sound signal from both the chassis control centre and the platform control centre.

- lift the boom about 1-2 metres (using lever 8) and extend the telescope 1-2 metres (using lever 9) keeping the emergency stop button depressed – the movement shall now stop
- using the emergency descent, retract first completely the telescope, then lower the boom
- pull up the emergency stop button
- test the operation of the sound signal

### 9.1.8. Decals, stickers and signs

Check that all the signs, warning decals and pictorials in the control centres are in place, intact and clean.

### 9.1.9. Instruction manuals

Check that the user manuals accompanying the lift are legible.

BLANK



BLANK



---

## 10. CHANGE OF OWNER

For the owner of the lift:

If you have purchased a used DINO lift from some other than the manufacturer, please post your details to the manufacturer using the form on this page, and send it to:

info@dinolift.com

This information makes it possible for us to provide you with the safety bulletins and other campaigns relevant to your machine.

Note! It is not necessary to inform about a rented machine.

Machine model: DINO \_\_\_\_\_

Serial number: \_\_\_\_\_

Previous owner: \_\_\_\_\_

Country: \_\_\_\_\_

Date of purchase: \_\_\_\_\_

Current owner: \_\_\_\_\_

Address: \_\_\_\_\_

\_\_\_\_\_

Country: \_\_\_\_\_

Contact person

Name and position in the company: \_\_\_\_\_

Telephone: \_\_\_\_\_

E-mail: \_\_\_\_\_

## NOTES

**NOTES**